

28	Remover o tubo.
----	-----------------

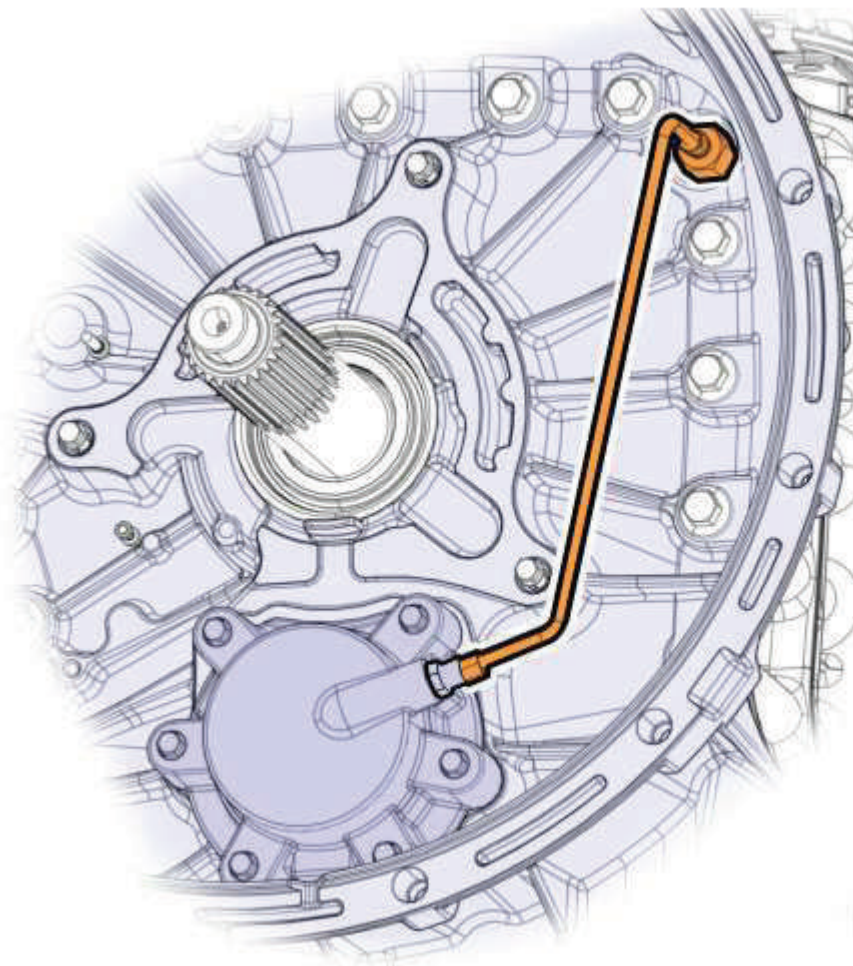

- | | |
|----|----------------------|
| 29 | Remova os parafusos. |
| 30 | Remover o cilindro. |
| 31 | Remover a junta. |

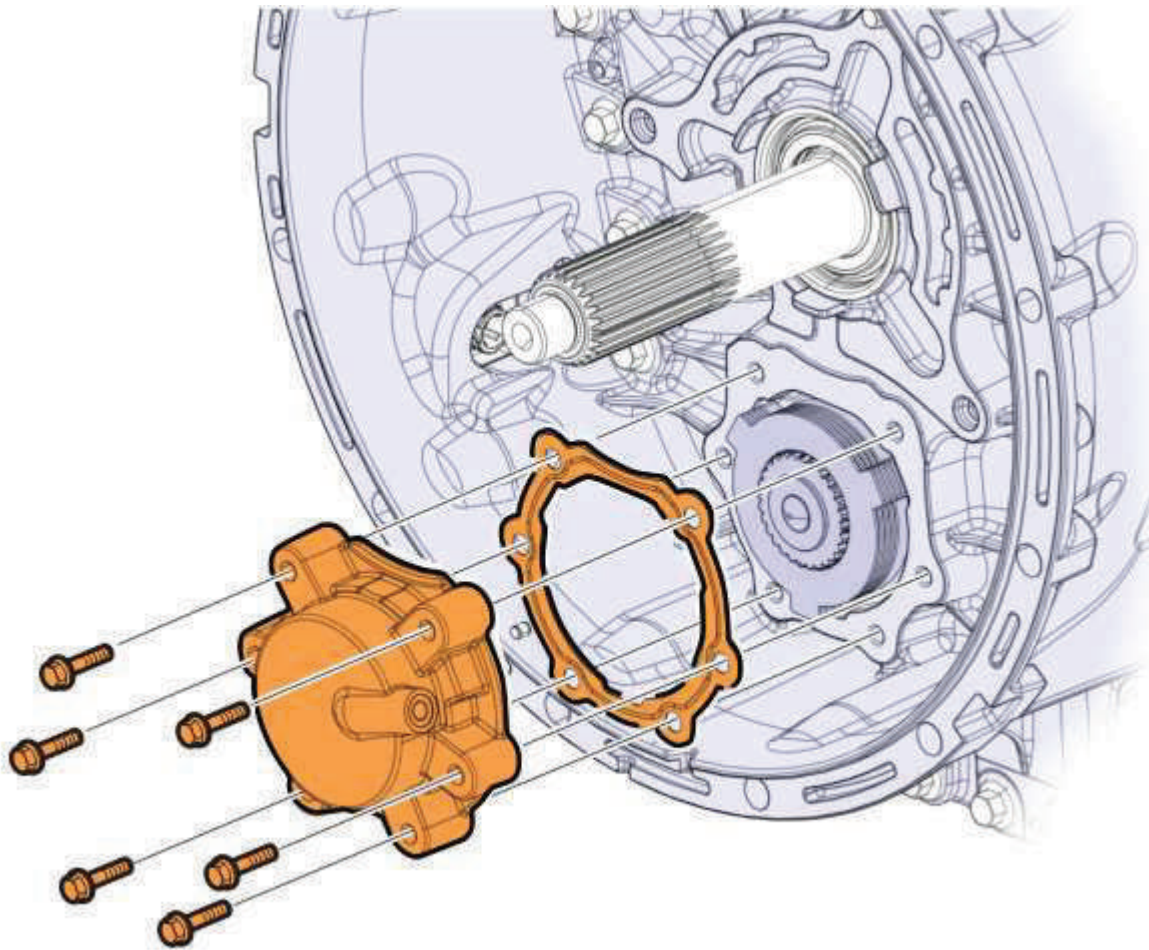

32 Remover o conjunto do disco.

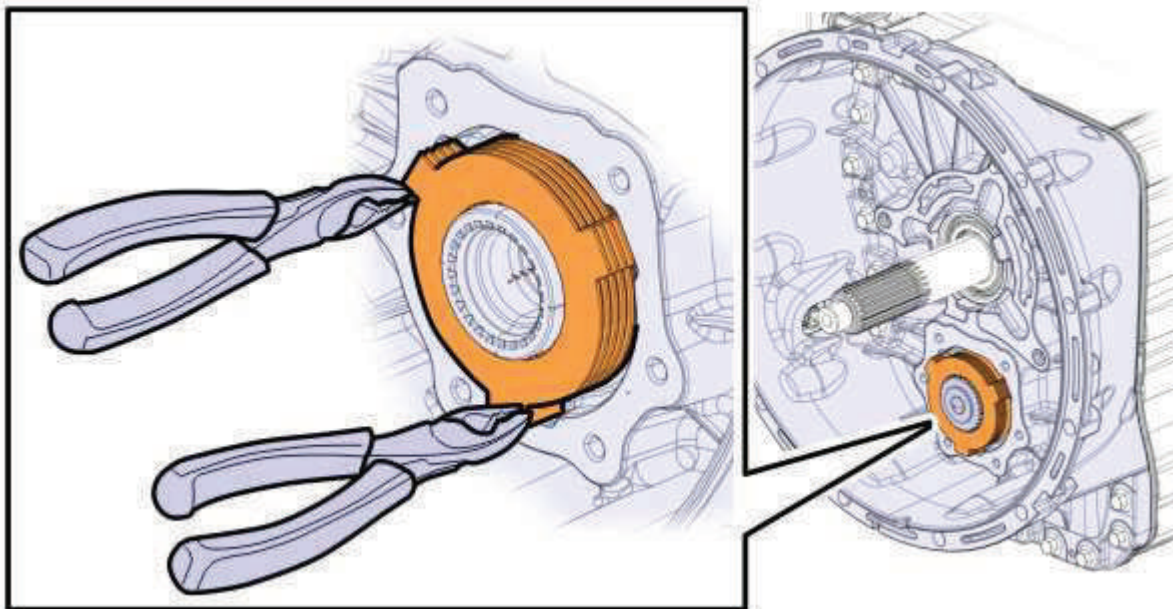

33 Posicionar o cilindro e a ferramenta em na morsa.

Material necessário

mandril



Nota

Usar mandíbulas macias na morsa para evitar danos ao componente.

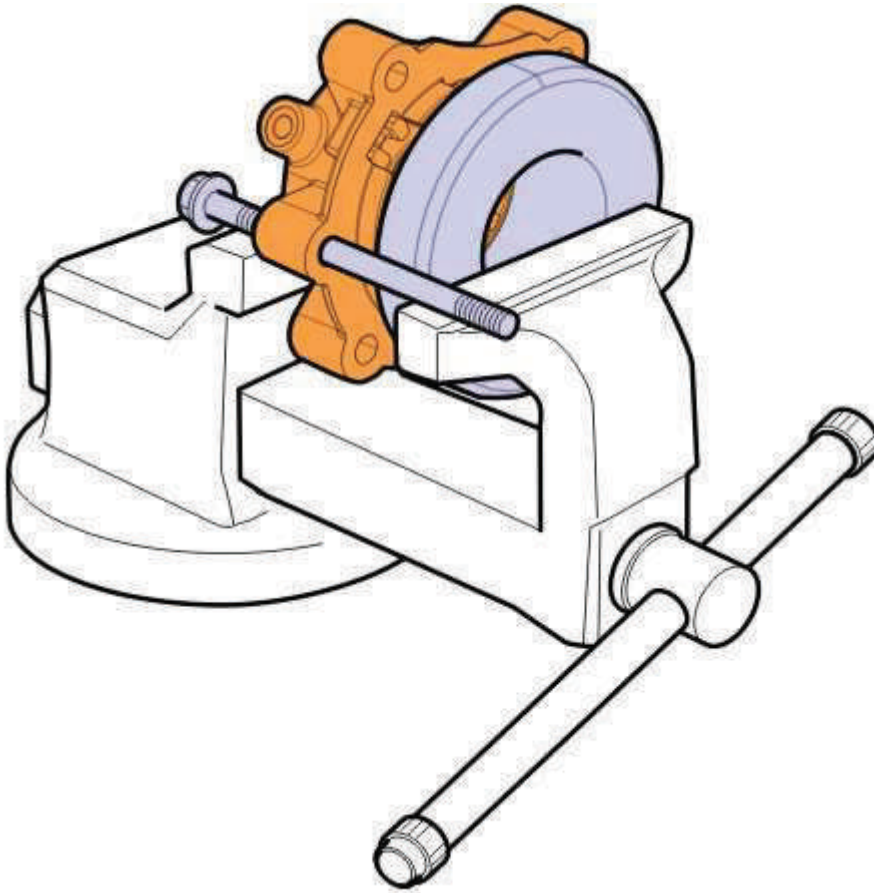

34	Remova a tampa.
	Material necessário
	mandril

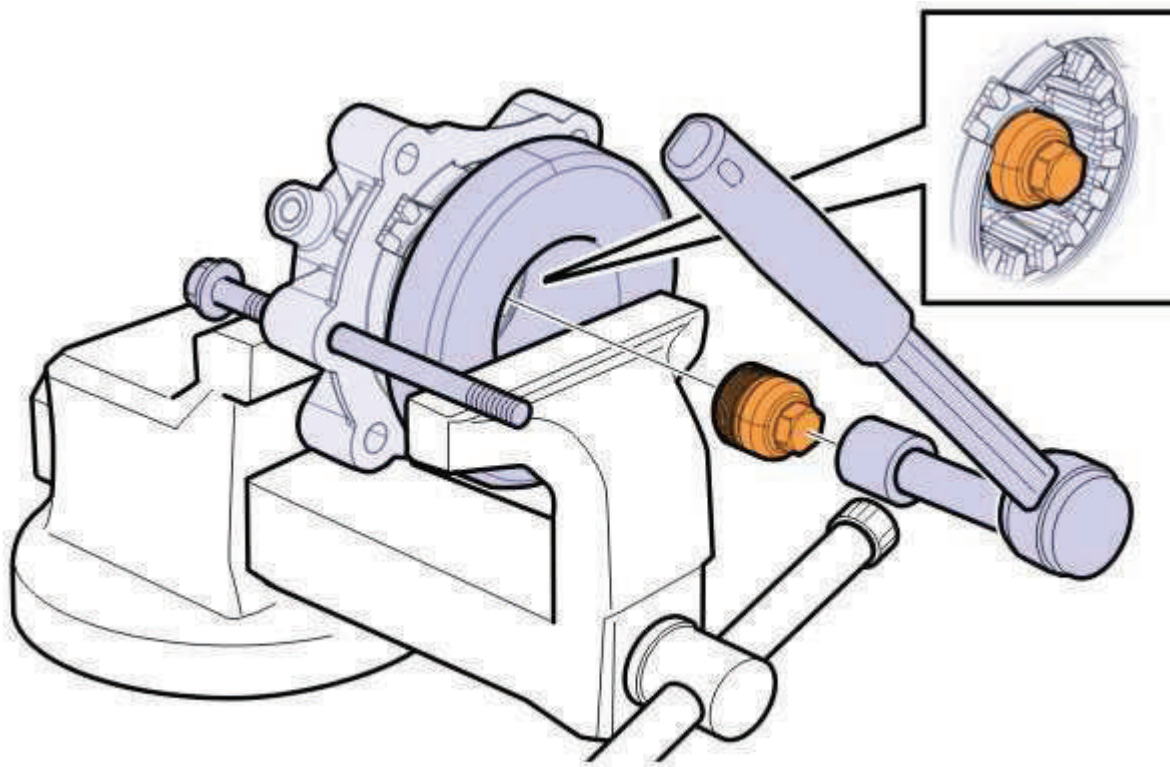

- | | |
|----|---------------------|
| 35 | Remover o parafuso. |
| 36 | Remover a arruela. |
| 37 | Remover a mola. |

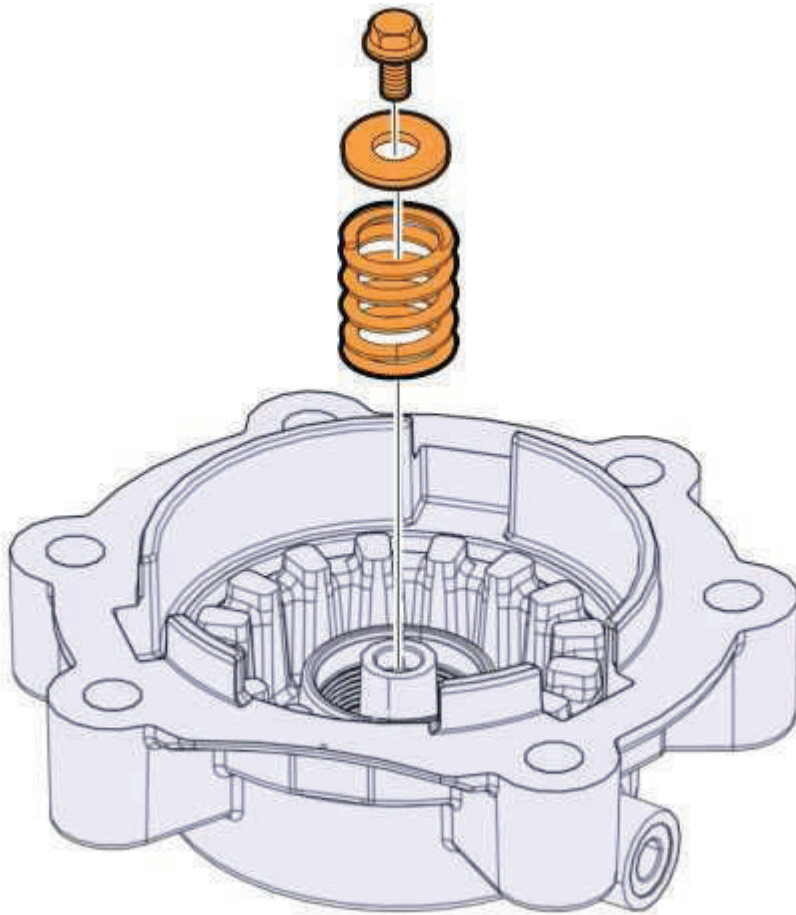

38 Instale a tampa.



Nota

Apertar manualmente.

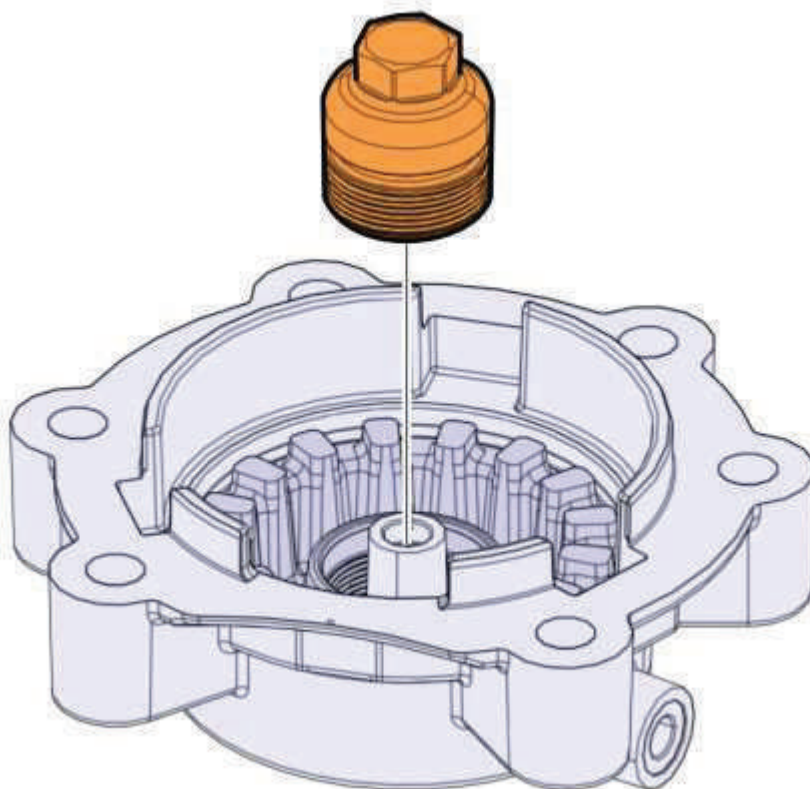

39 Injete ar comprimido.



Nota

Certifique-se de que o pistão aponte para a bancada de trabalho.



Nota

Posicione o pistão na superfície de borracha para evitar danos.

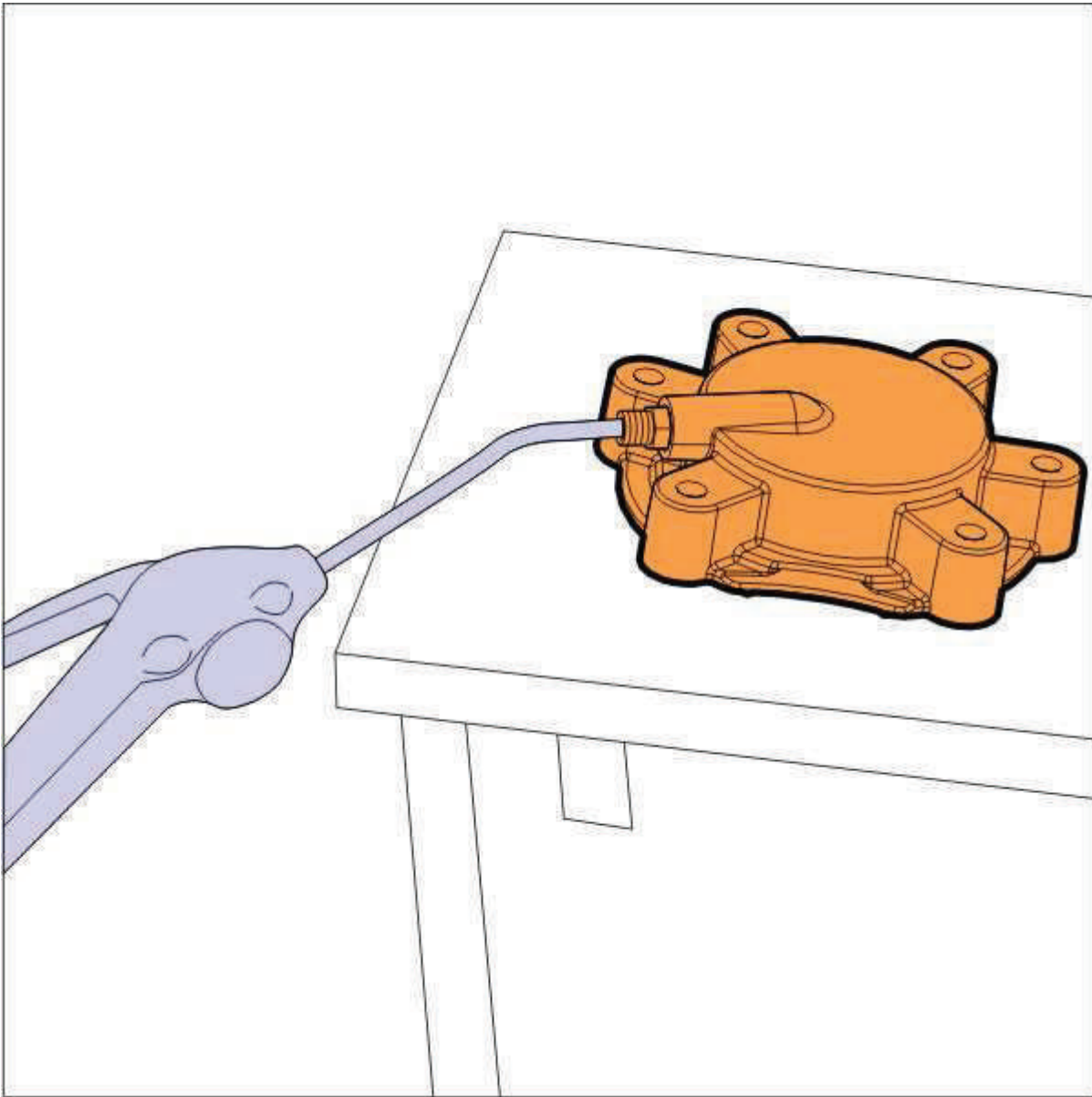

40 | Remover o pistão.

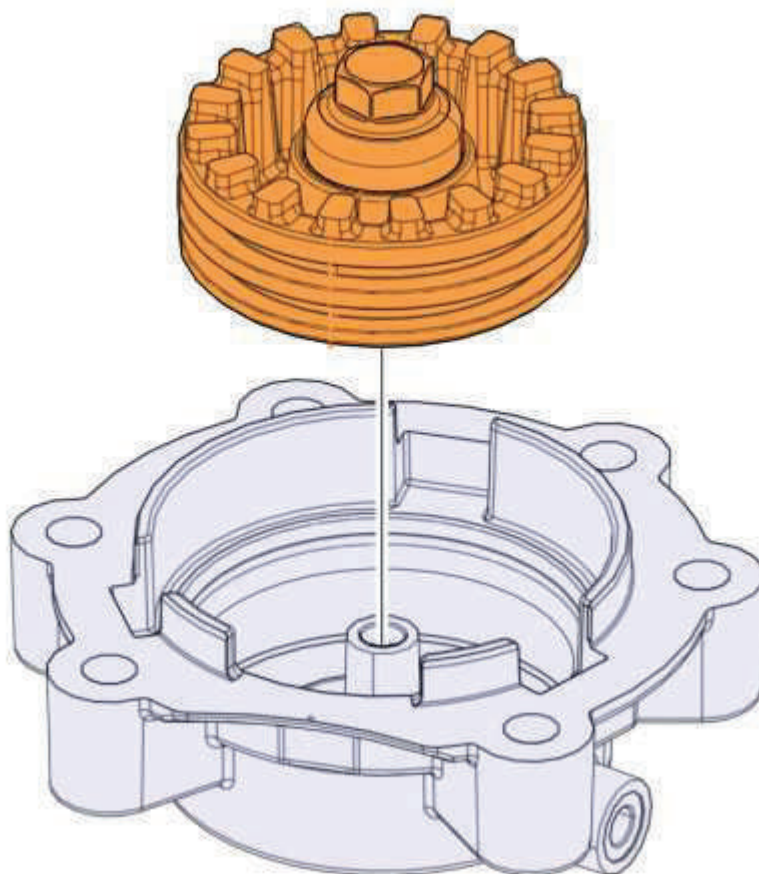

41 Remova a tampa.

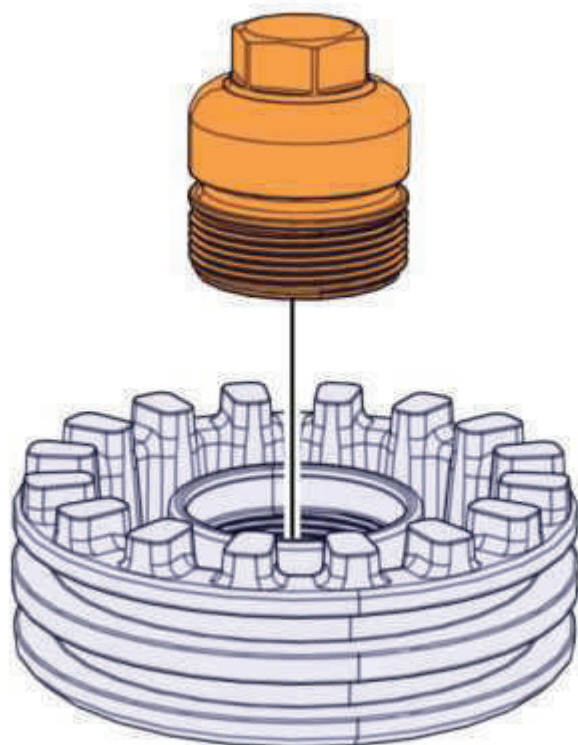

42 Remova as vedações.

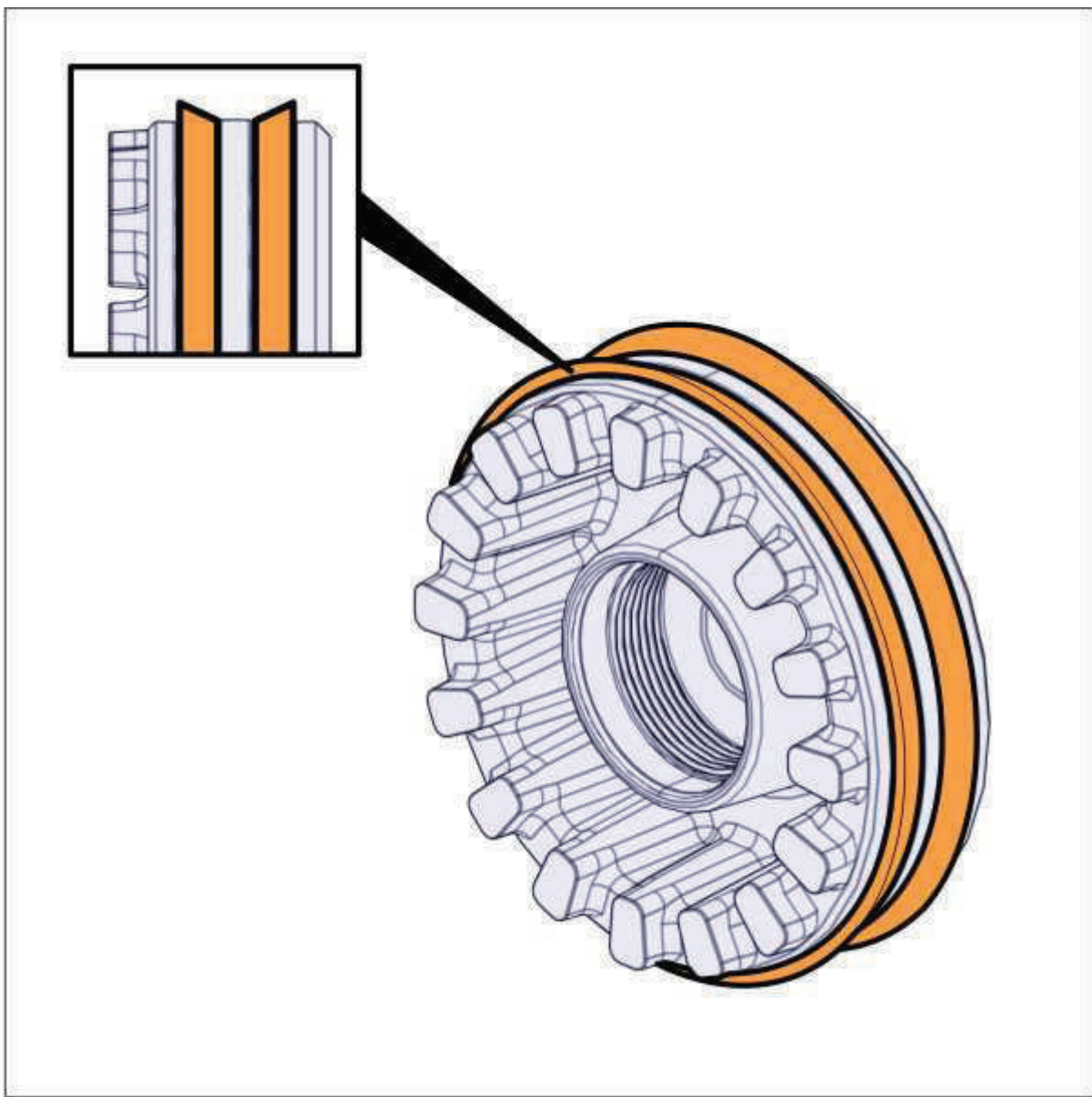

43 Instalar um parafuso na vedação.



Nota

Usar um parafuso da de metal para chapa.

44 Remova a vedação.



Nota

Usar uma barra de remoção.

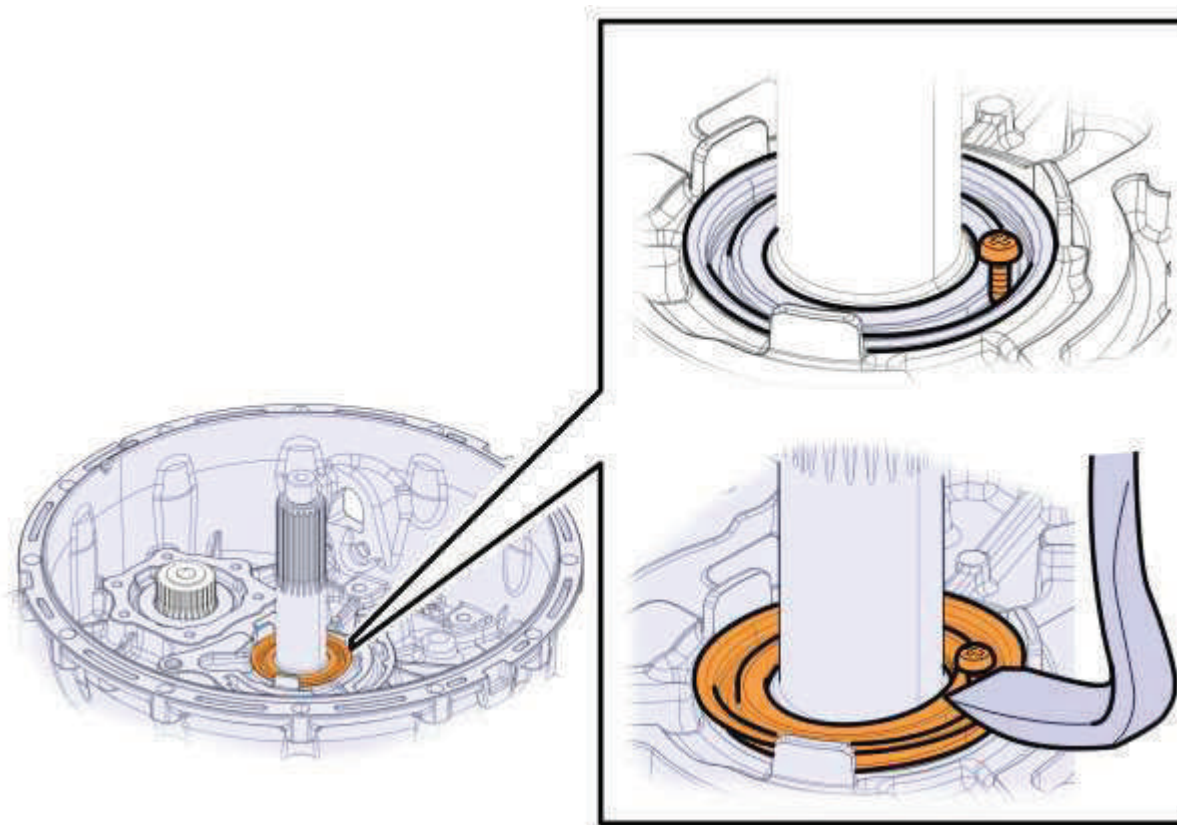

45	Instale as ferramentas.	
	Material necessário	
	BOMBA HIDRÁULICA	_____
	PUNÇÃO OCO	_____
	mandril	_____
	cilindro hidráulico	_____

46	Remover o eixo de entrada.
-----------	----------------------------

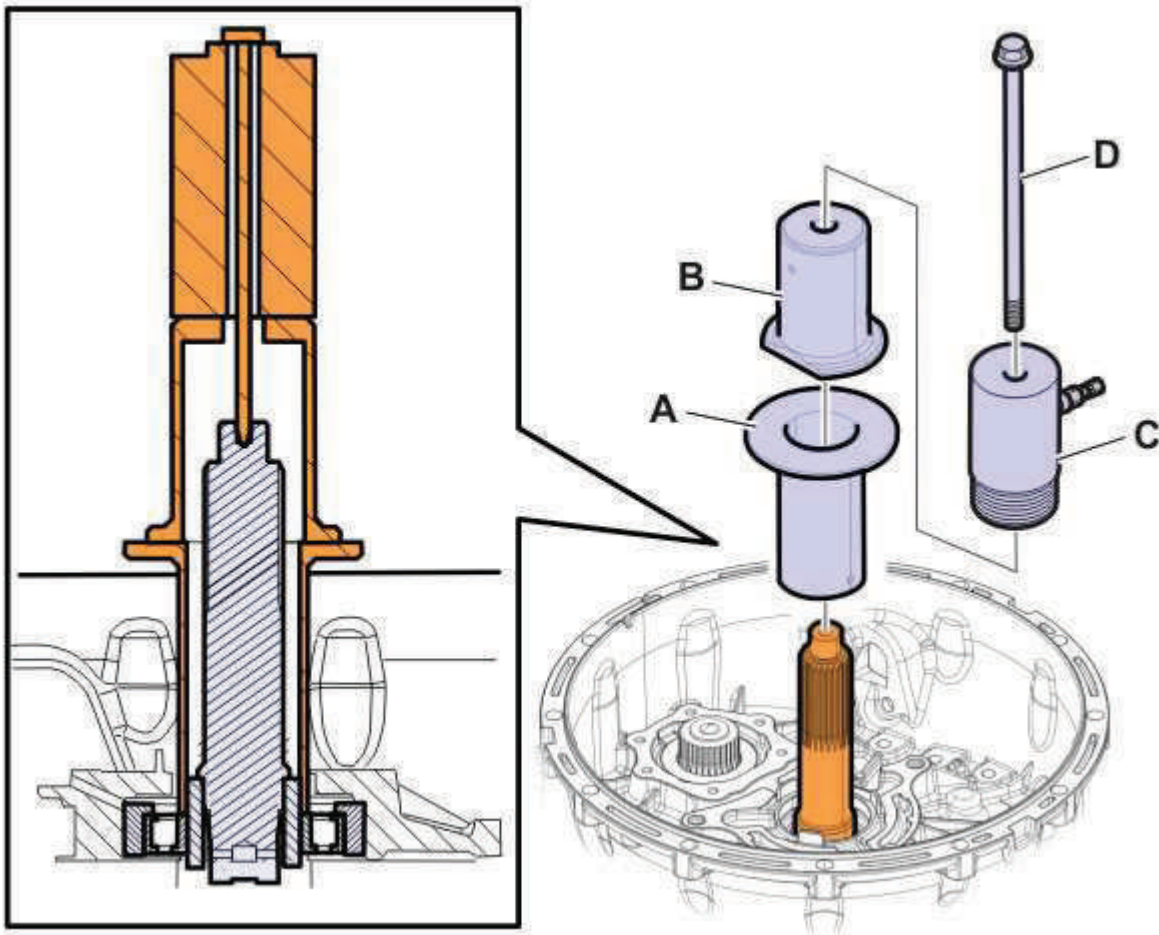

A	<u>PUNÇÃO OCO</u>
B	<u>mandril</u>
C	<u>cilindro hidráulico</u>
D	Parafuso, M8.

47 Remover os parafusos.

48 Remova a carcaça.

Material necessário

BARRA DE FERRO



Nota

Usar uma barra de remoção.

49 Remover a junta.

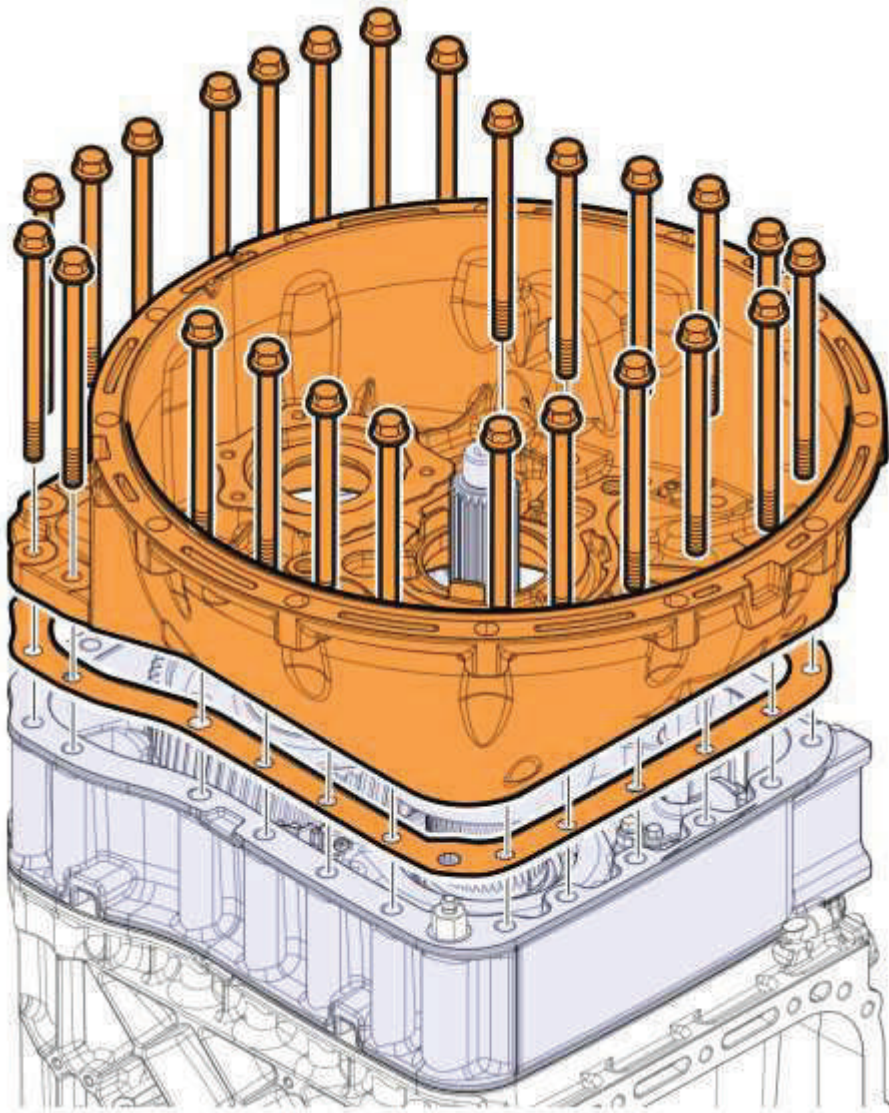

50	Remover a pista do rolamento.	
	Material necessário	
	mandril	_____
	sacador	_____
	mandril	_____

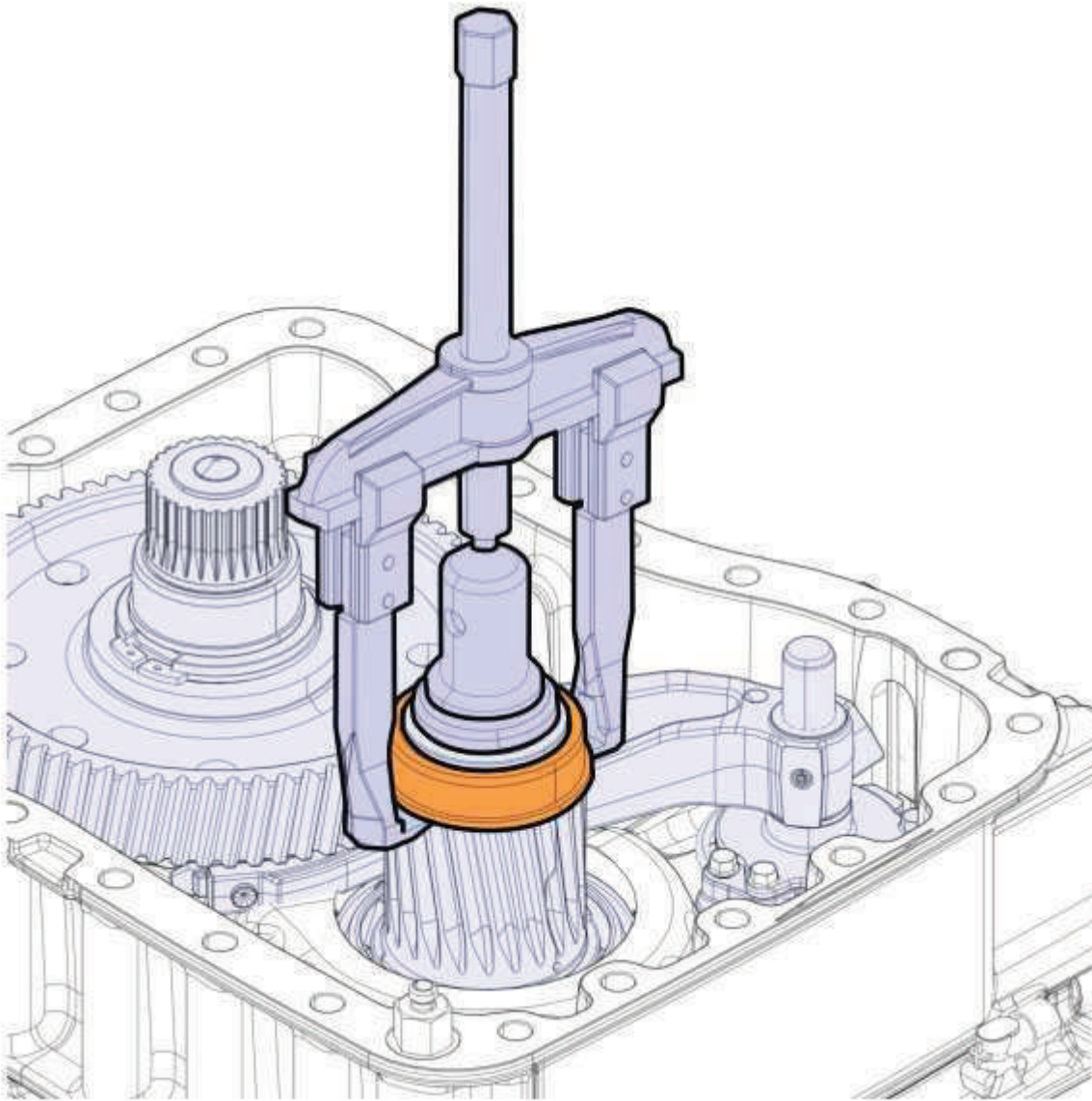

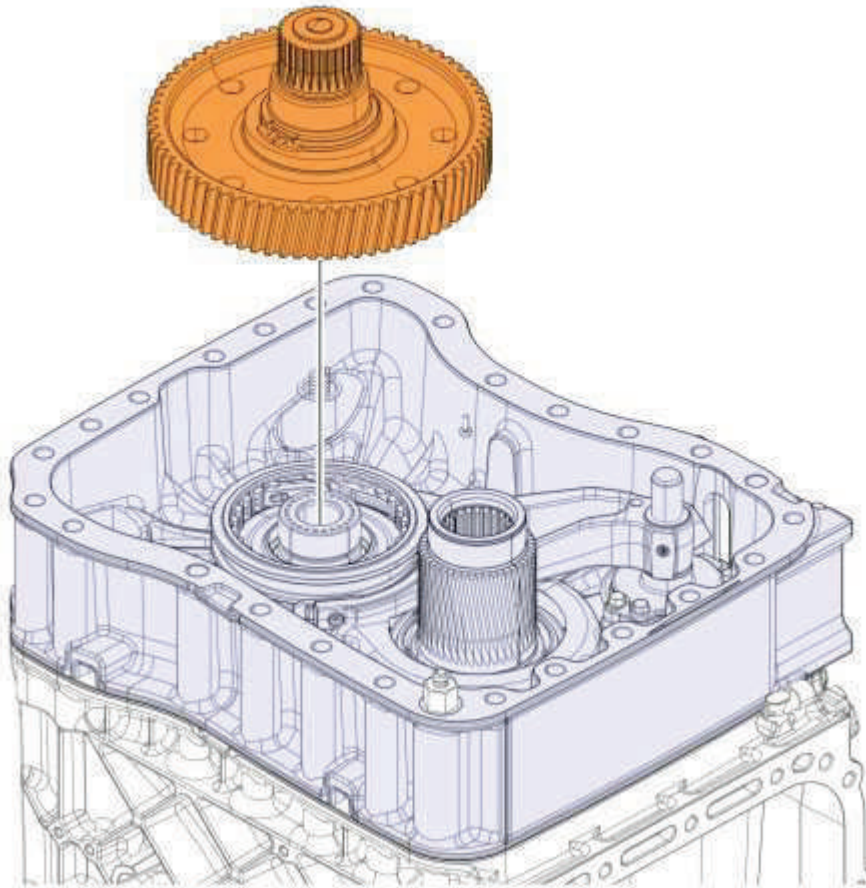

51 Remover o conjunto da engrenagem.

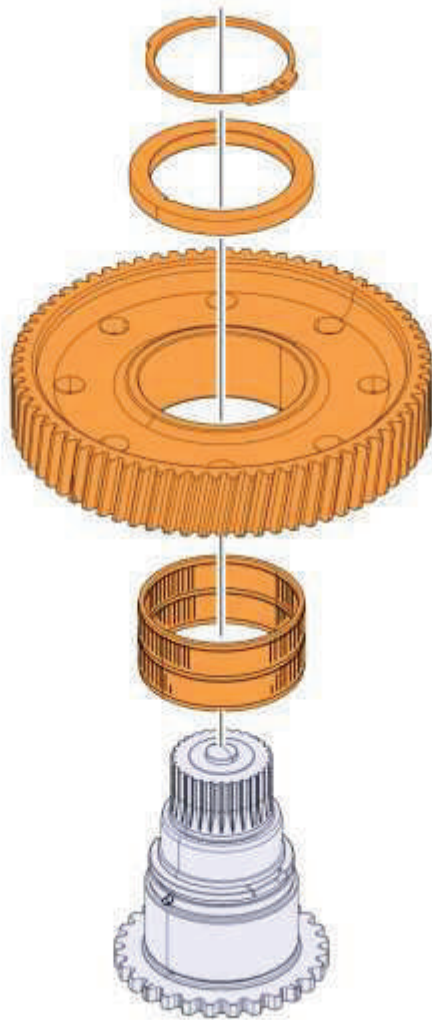

- | | |
|----|-----------------------|
| 52 | Remover o anel-trava. |
| 53 | Remover o espaçador. |
| 54 | Remover a engrenagem. |
| 55 | Remover o rolamento. |



56	Remover a pista do rolamento.	
	Material necessário	
	sacador	
	mandril	

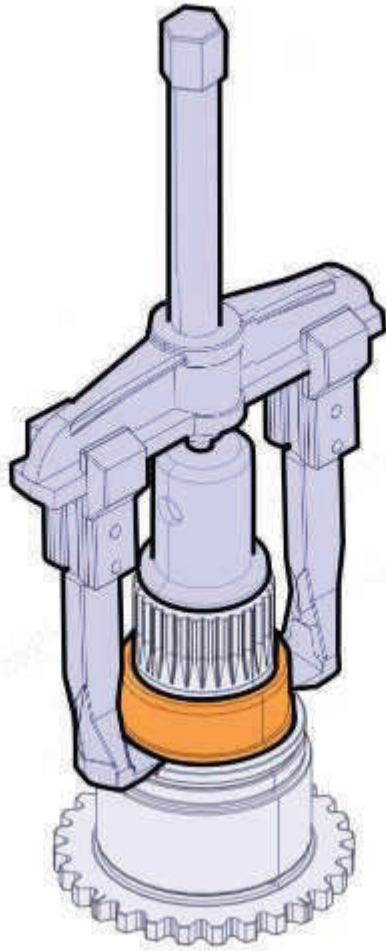

- | | |
|----|--------------------------|
| 57 | Remover os parafusos. |
| 58 | Remover o garfo seletor. |
| 59 | Remover a luva. |

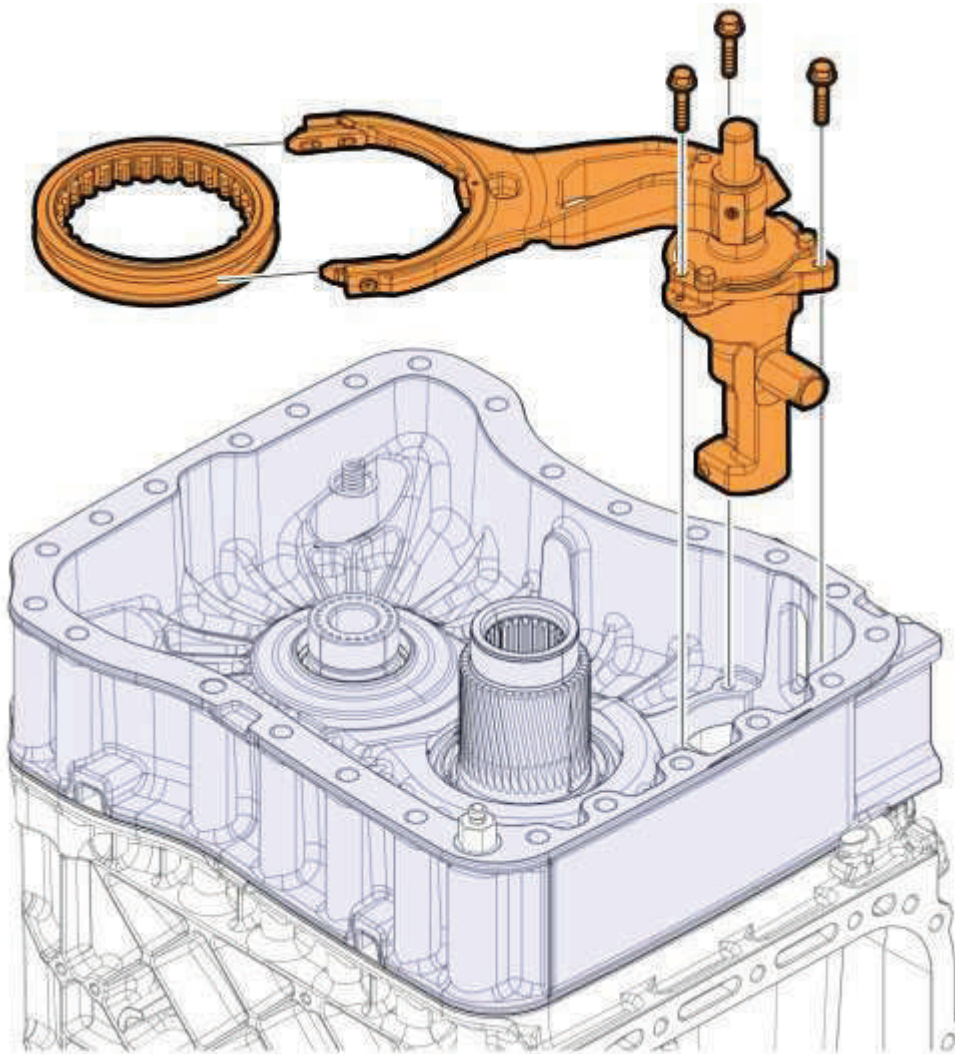

60	Remover o pistão de bloqueio (3).
61	Remover os parafusos (1).
62	Remover o cilindro.
63	Remover o pino (2).
64	Remover o pino da mola (4).
65	Remover o eixo. <div data-bbox="161 1588 480 1688" style="border: 1px solid black; padding: 5px;"> i Nota Observar a posição. </div>

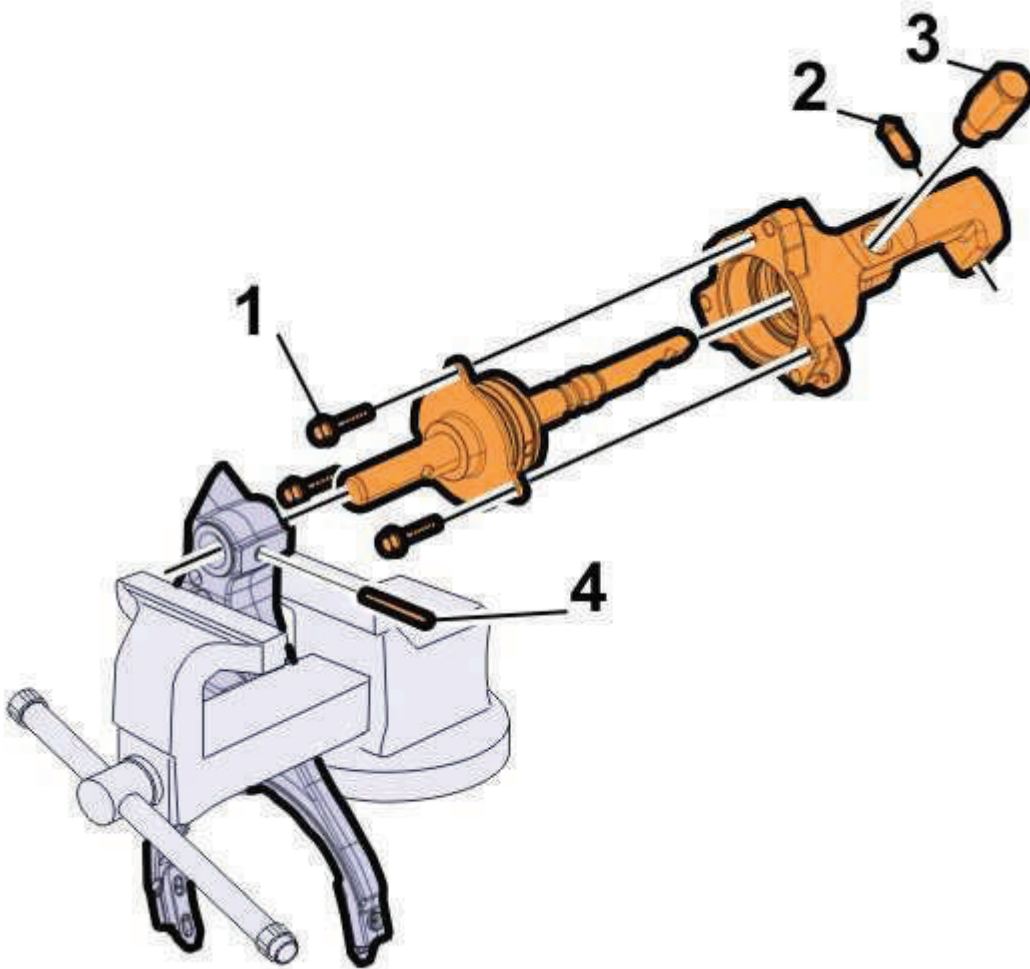

66 | Remover a vedação.

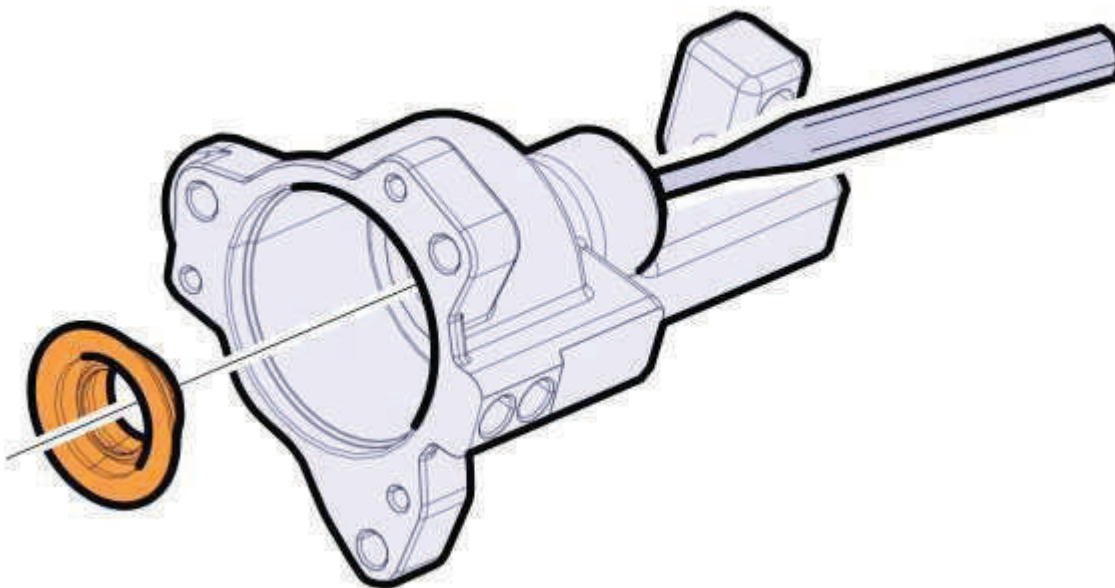

67 | Remova a carcaça.

68 Remover a junta.

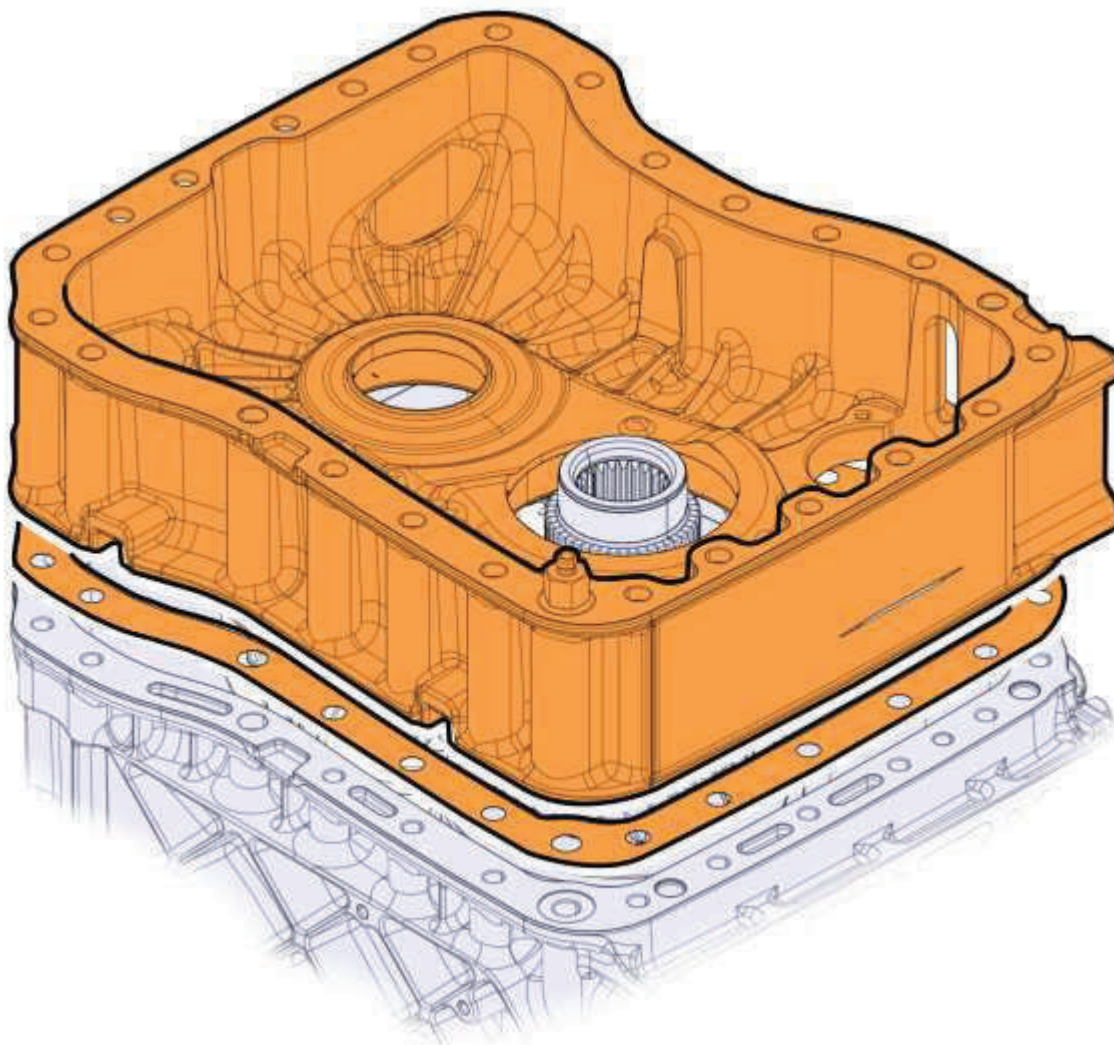

69 Verificar se os rolamentos apresentam desgaste e dano.

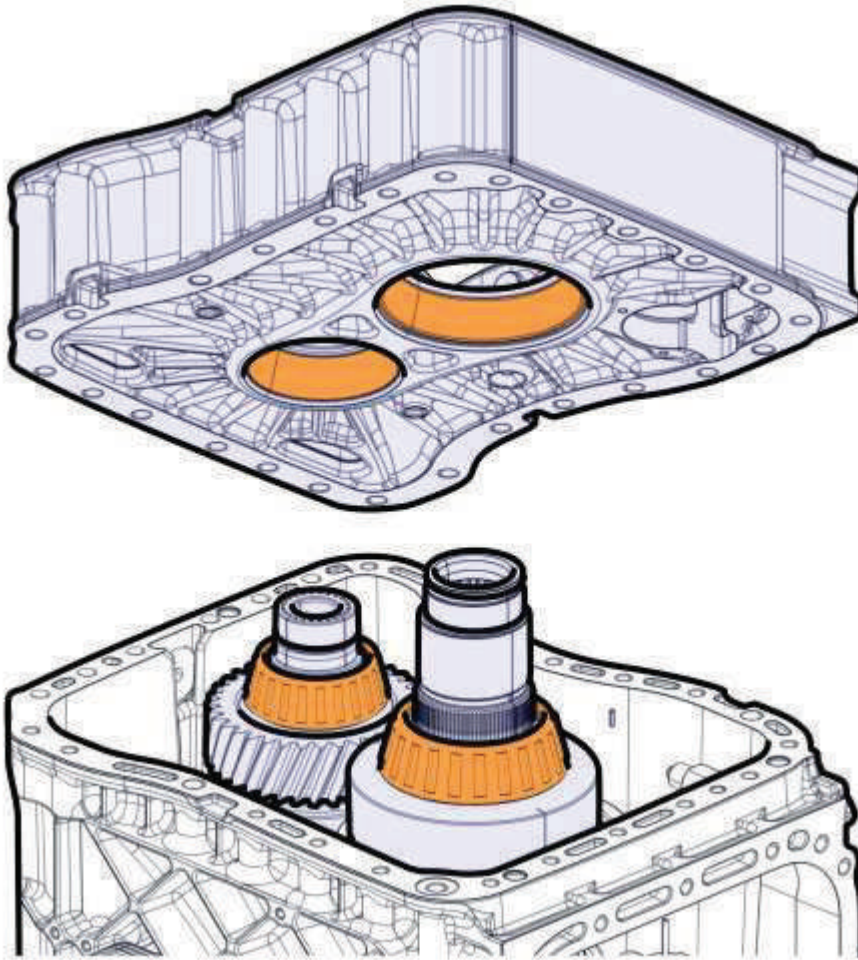

70	<p>Execute este procedimento quando a condição abaixo for atendida.</p> <p>Condições</p> <ul style="list-style-type: none"> • Se a carcaça ou os rolamentos forem trocados. <p>▶ Ajustar a pré-carga no eixo principal e no eixo intermediário.</p>
71	Limpar todas as peças.
72	<p>Verifique se as peças apresentam desgaste ou dano.</p> <div style="border: 1px solid black; padding: 5px; margin-top: 10px;"> <p>i Nota Trocar peças danificadas e desgastadas.</p> </div>
73	<p>Lubrificar as peças.</p> <p>Material necessário</p> <p>Óleo da caixa de mudanças</p>
74	<p>Lubrificar os rolamentos e as pistas externas.</p> <div style="border: 1px solid black; padding: 5px; margin-top: 10px;"> <p>i Nota Usar o óleo recomendado.</p> </div>