

▶ Remova a junta.

▶ Remova a vedação.

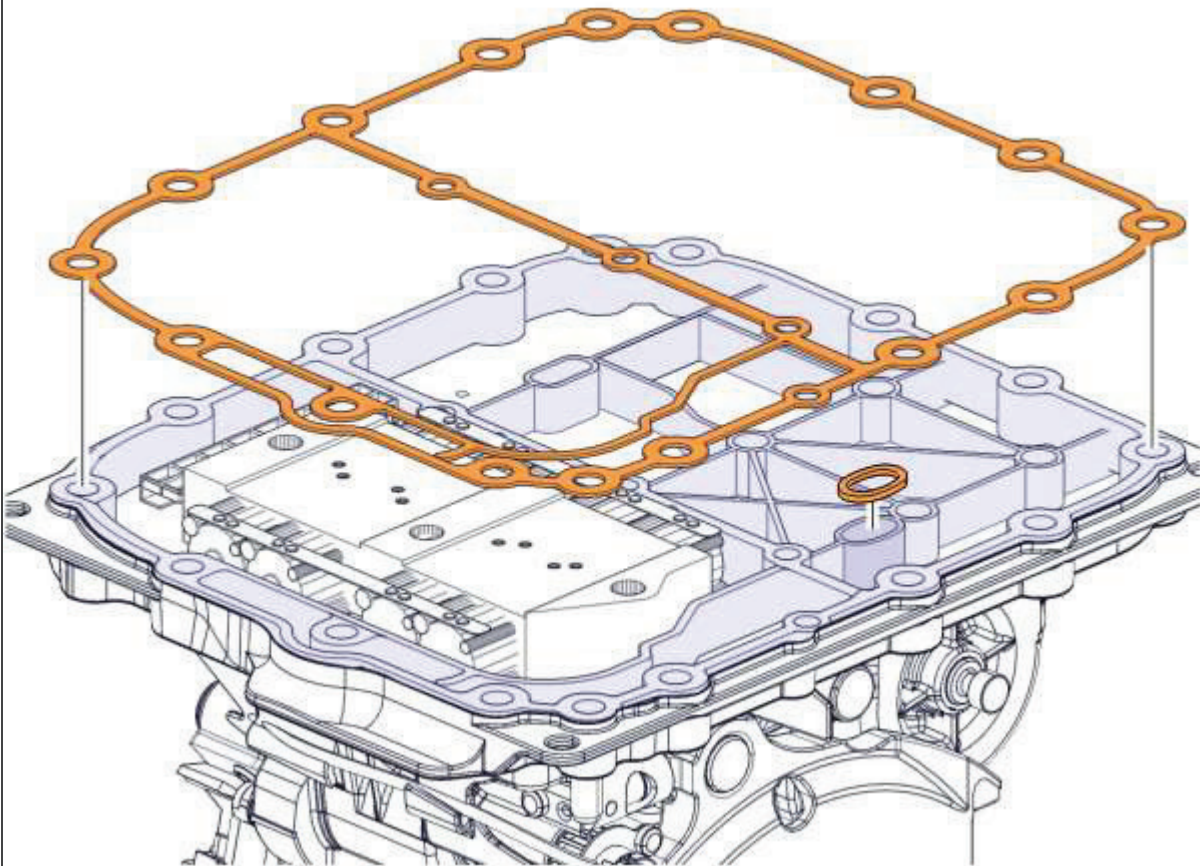

▶ Remova os parafusos.

▶ Remover a válvula.

► Remova a junta.



**Nota**

Não descartar a junta.

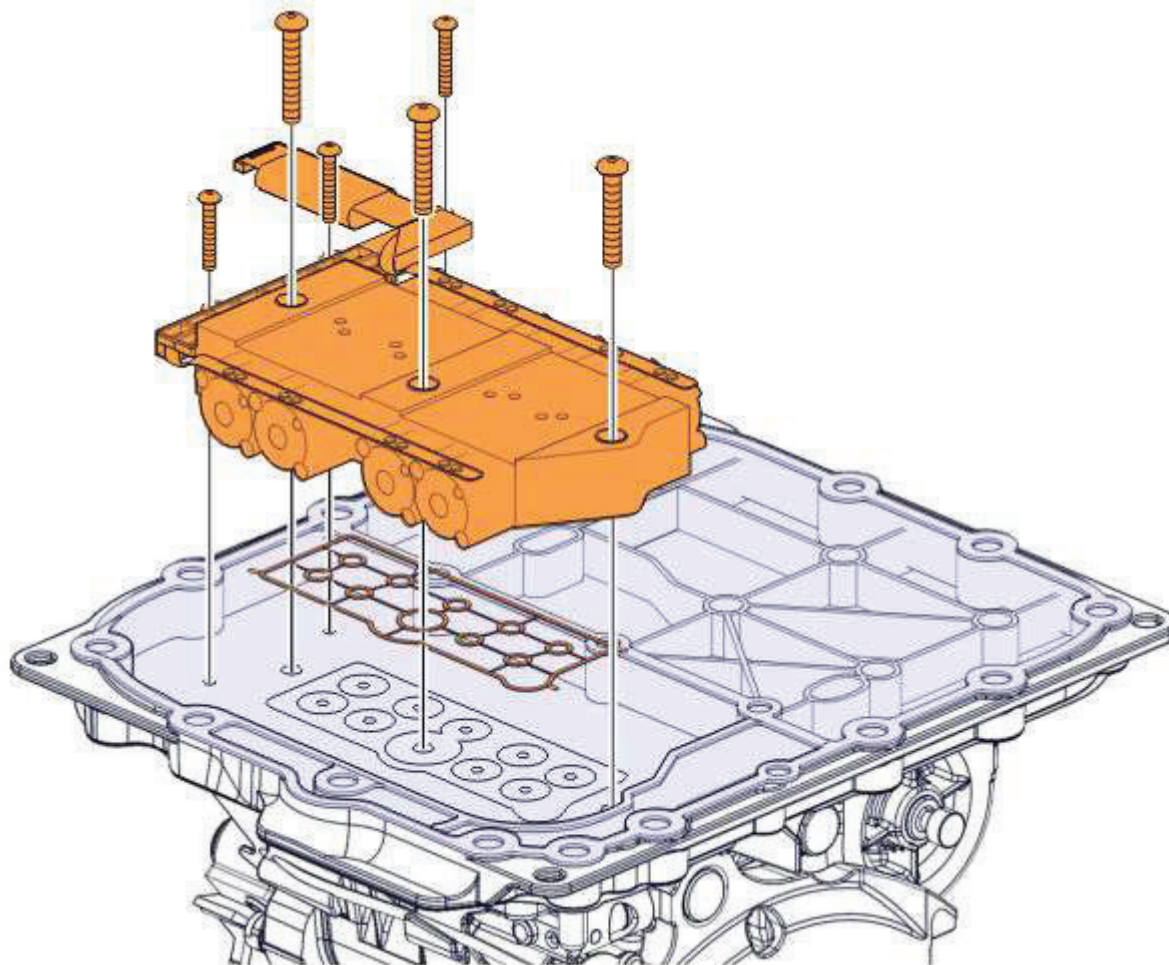

► Instalar os parafusos.



**Nota**

Usar 2 parafusos menores para prender temporariamente a carcaça de controle.

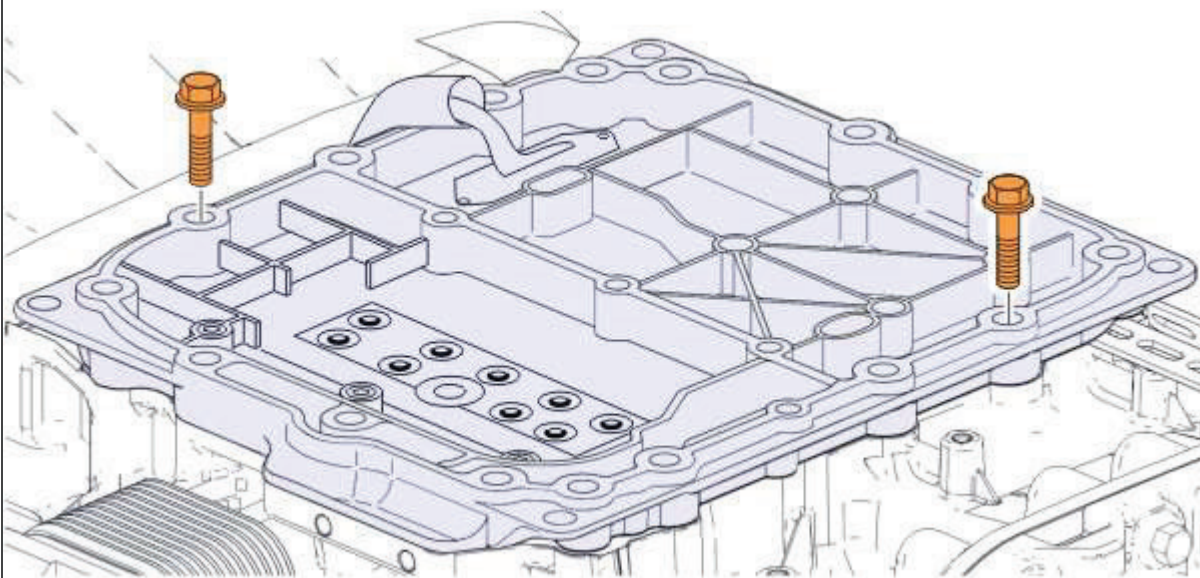

- ▶ Ative as engrenagens.
- ▶ Soprar ar nos furos para mover os garfos seletores para as posições corretas.
- ▶ Sopre ar dentro do furo (1).
- ▶ Sopre ar dentro do furo (4).
- ▶ Sopre ar dentro do furo (7).
- ▶ Sopre ar nos furos (9) e (2) ao mesmo tempo para posicionar a luva em neutro.

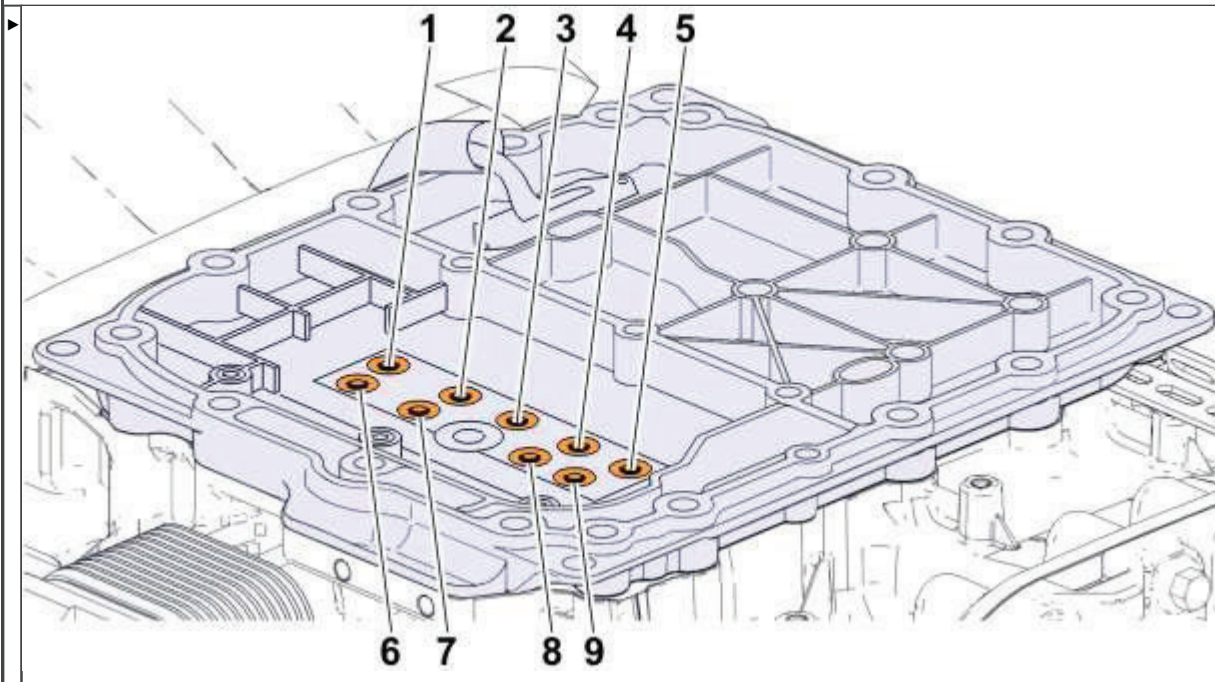

1	Ré
2	2ª marcha
3	Faixa baixa

4	Faixa alta
5	1ª marcha
6	Freio, eixo intermediário
7	Divisão alta
8	Divisão baixa
9	3ª marcha

▶ Remova os parafusos.

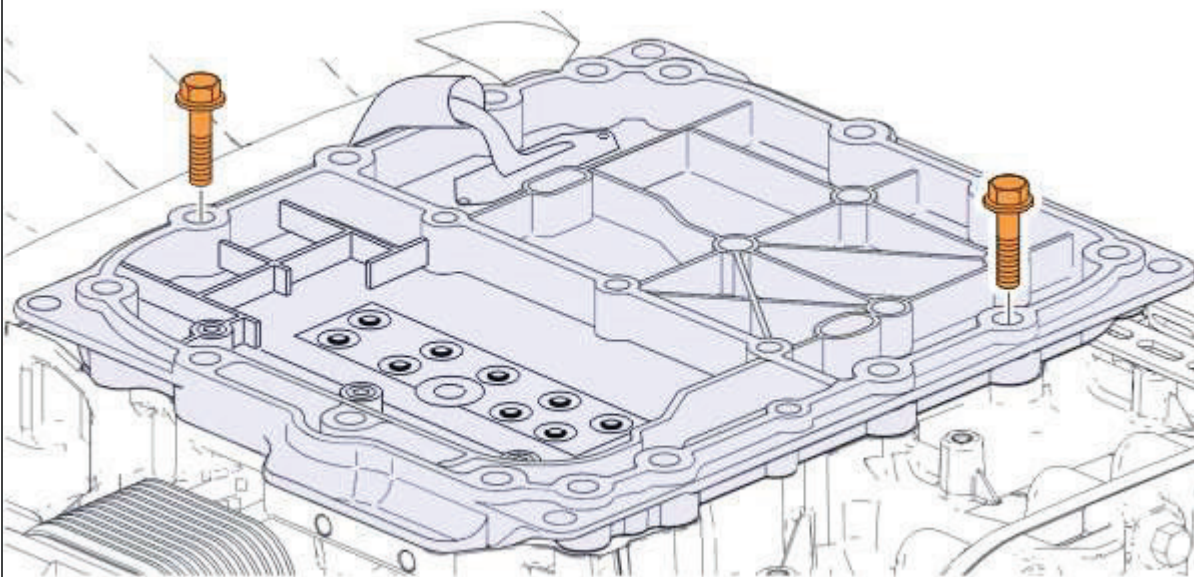

▶ Remover o alojamento do controle.

▶ Remova a junta.

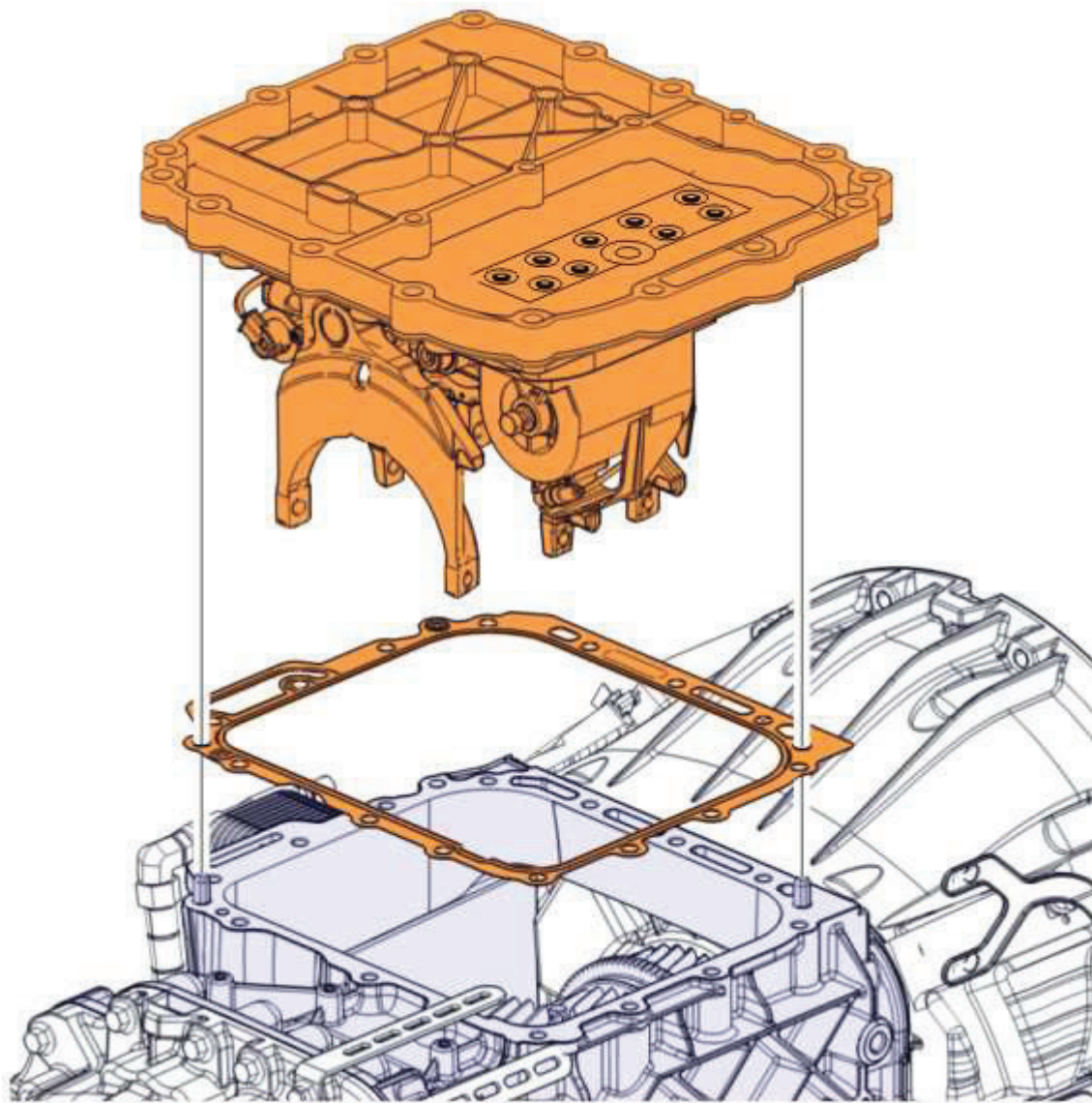

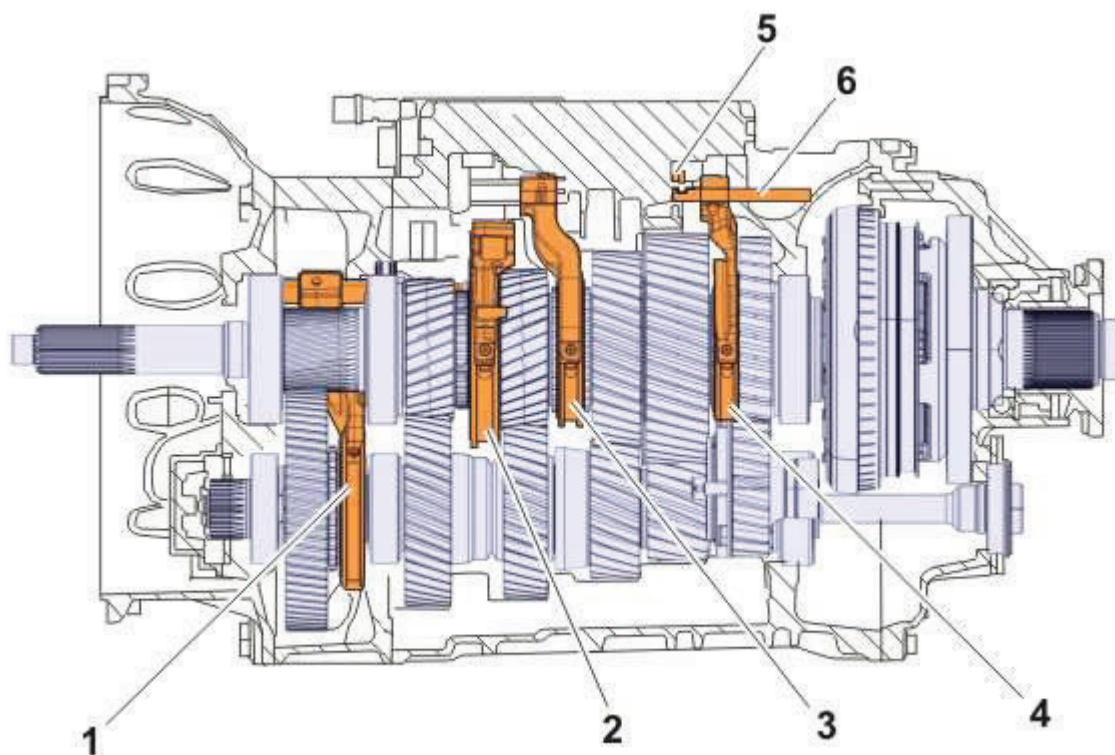

1	Luva de engate do da marcha reduzida
2	Luva de engate da engrenagem do divisor
3	Luva de engate da segunda e terceira marcha
4	Luva de engate da primeira marcha e da marcha à ré
5	Pistão do cilindro de faixa
6	Eixo da alavanca de câmbio de faixa

**36** Posicionar um recipiente de drenagem.

**37** Remova os tubos.

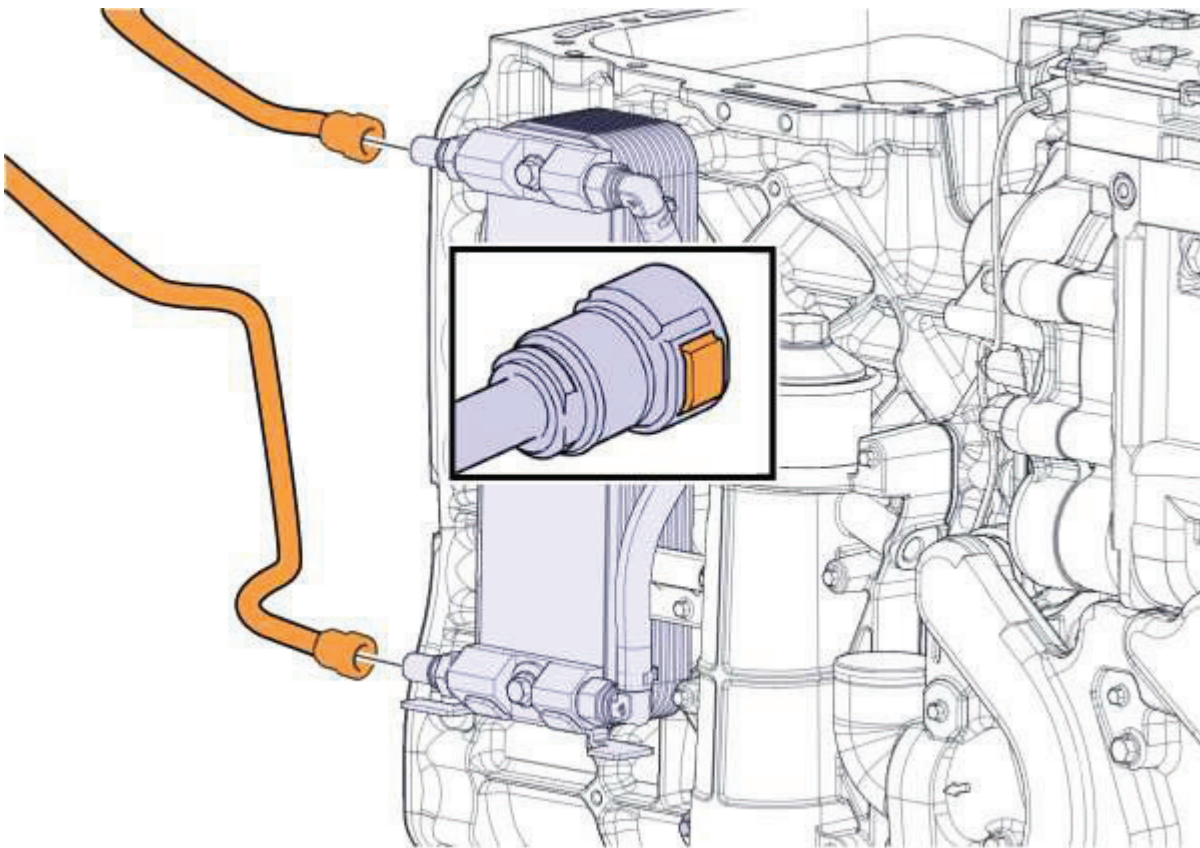

38 Remover os parafusos.

39 Remover o suporte.

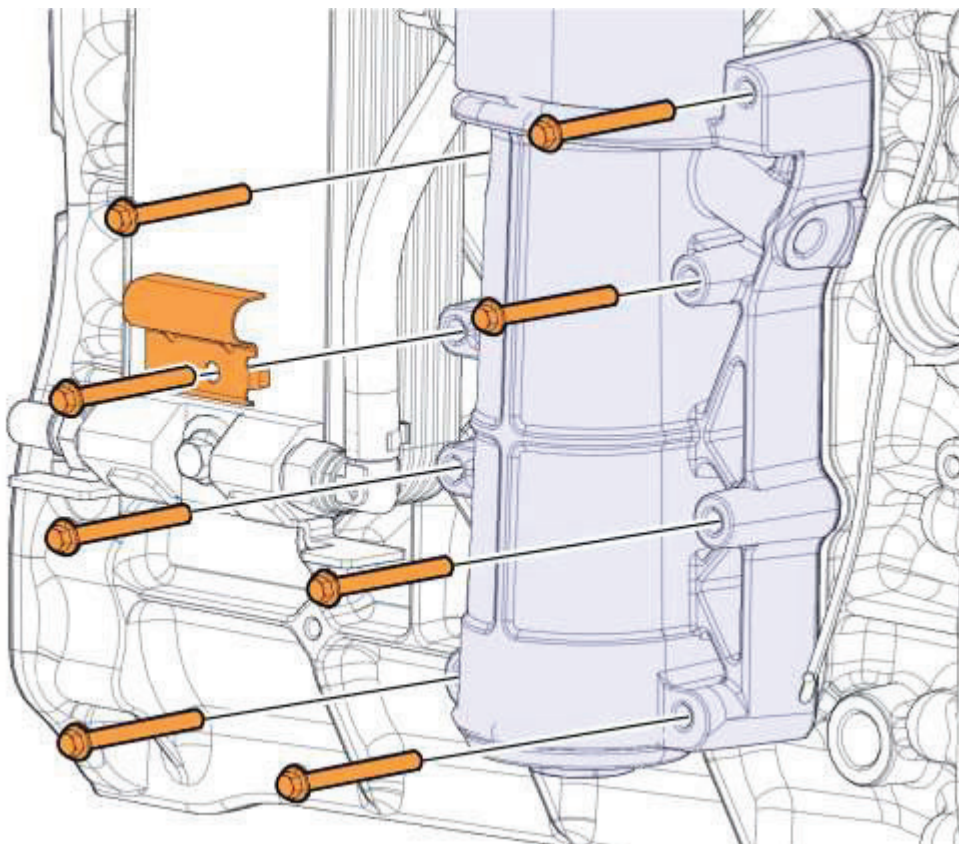

40 Remover os parafusos.

41 Remover o suporte.

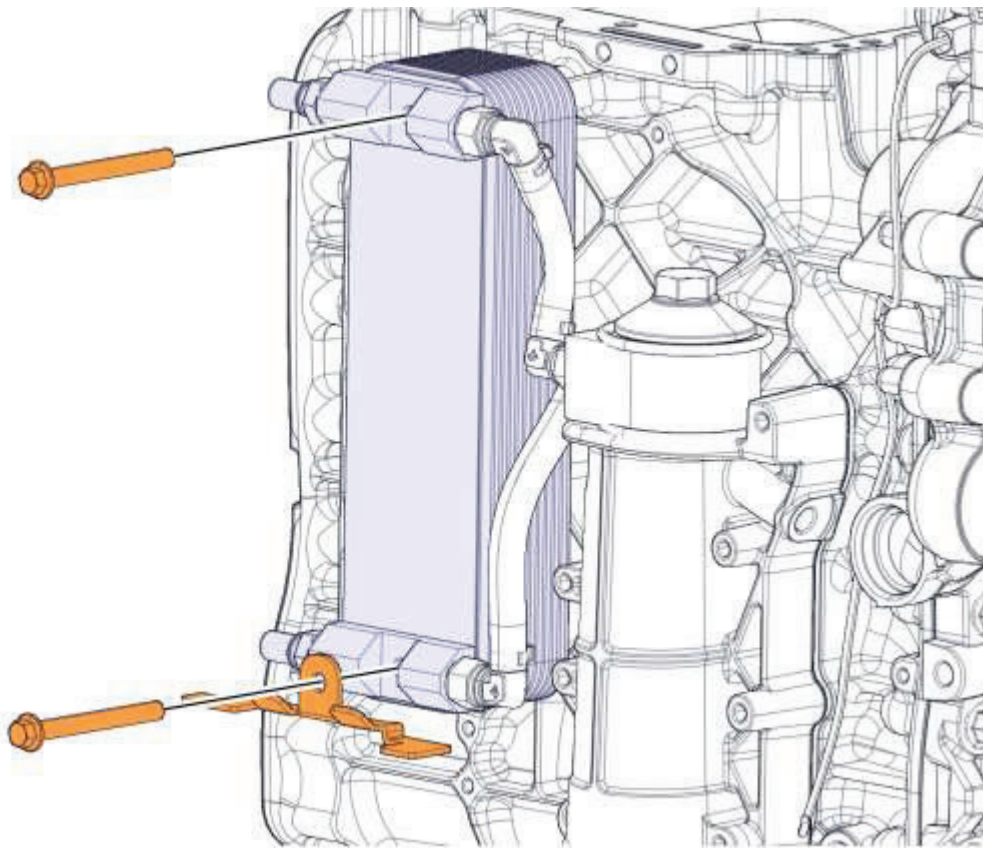

42 Remover o conjunto do filtro de óleo.

43 Remova a junta.

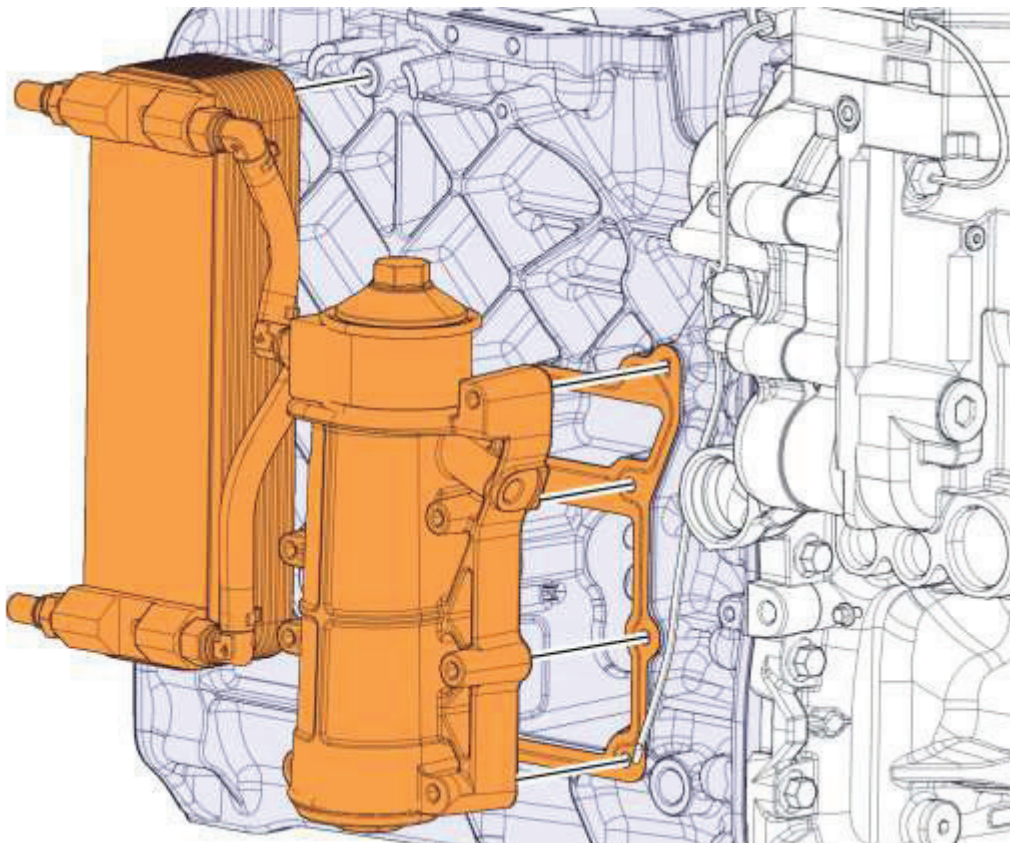



44	Remover o tubo.
<b>Material necessário</b>	
jogo	

45	Remover as braçadeiras de cabo.
----	---------------------------------

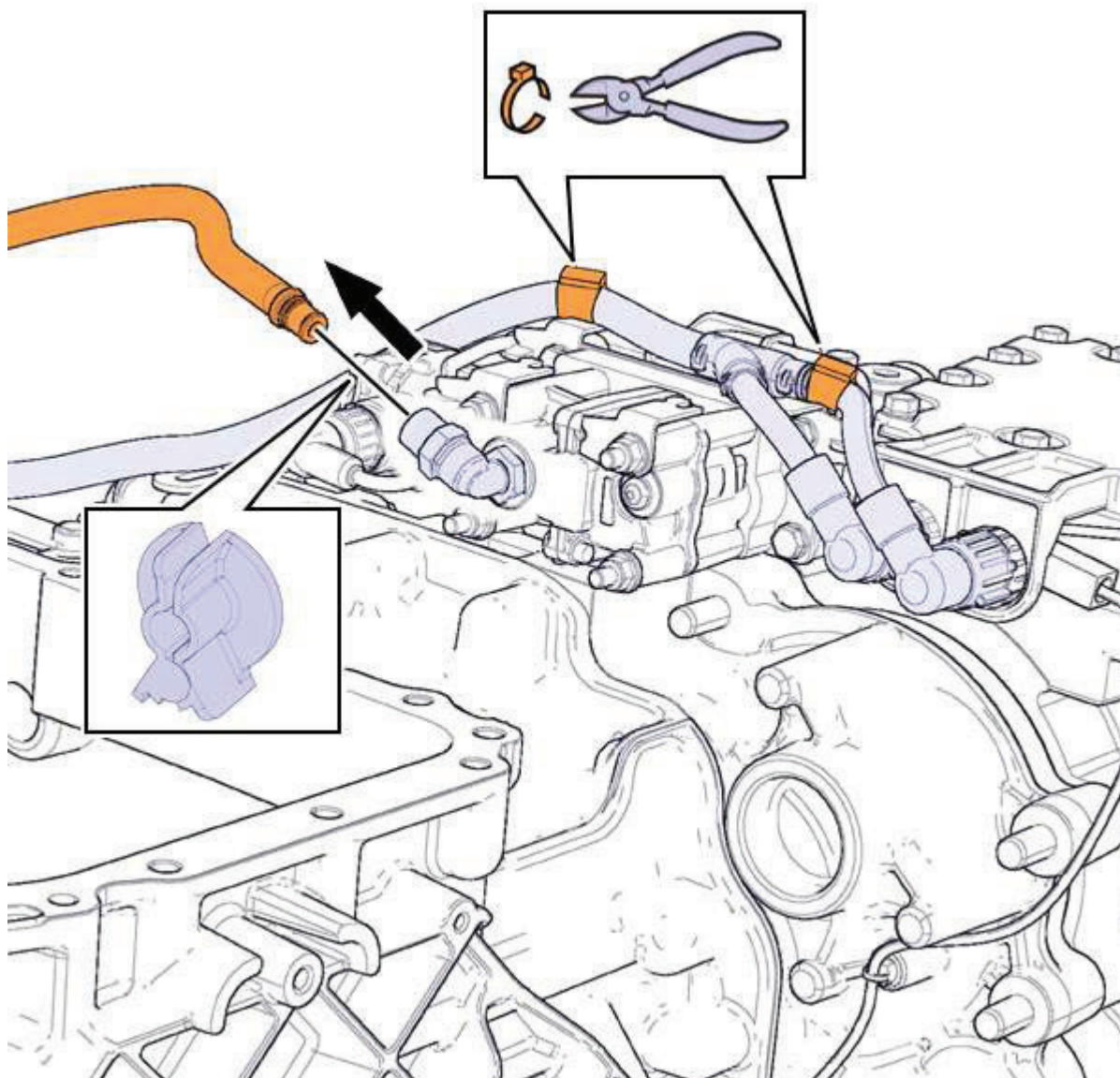

46	Desconecte os conectores (1).
----	-------------------------------

47	Remover a tampa (2).
----	----------------------

48	Remover o chicote elétrico (3).
----	---------------------------------

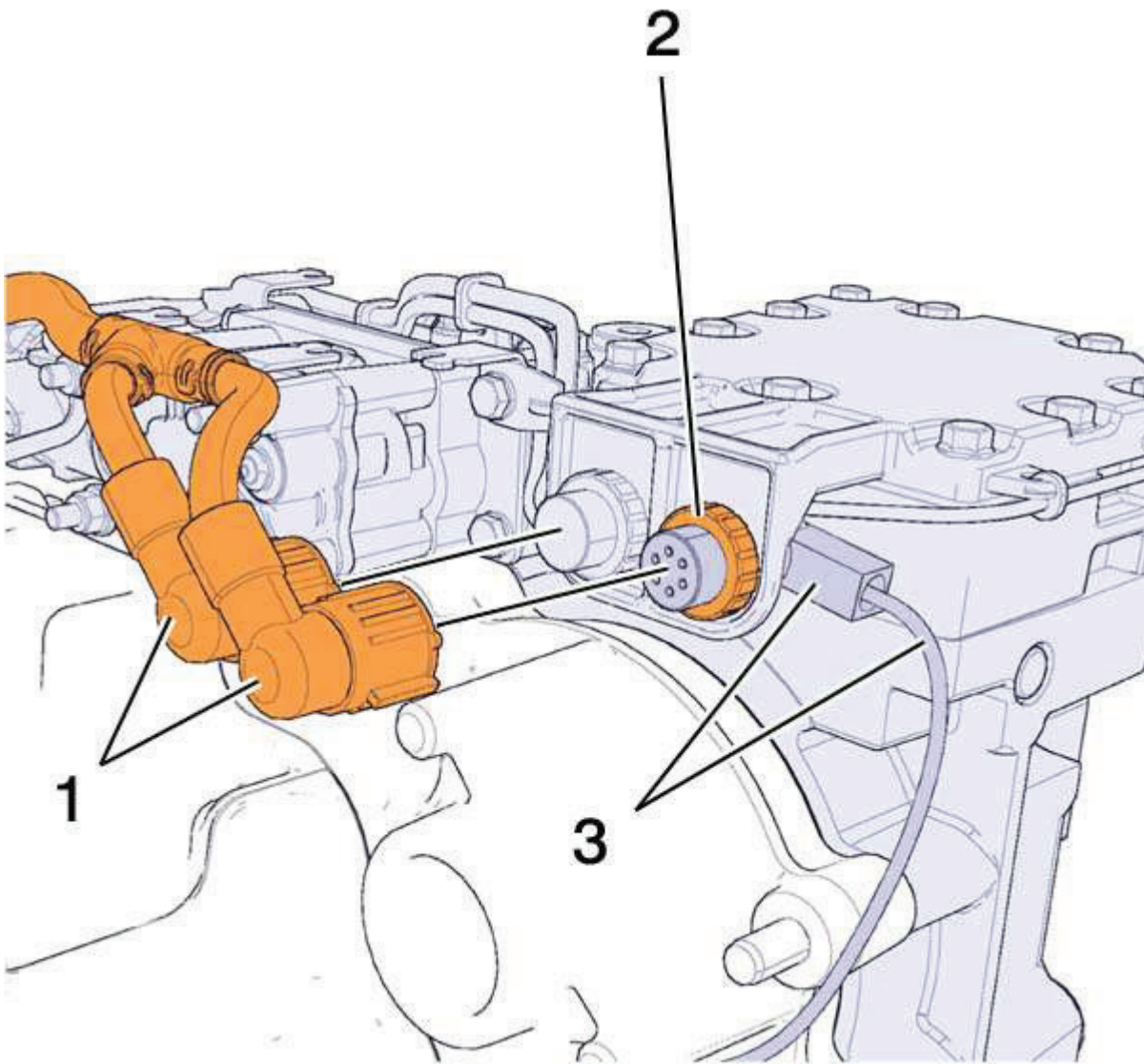

49	Remova o parafuso (1).
50	Remover a braçadeira de cabo.
51	Afrouxar o chicote elétrico.

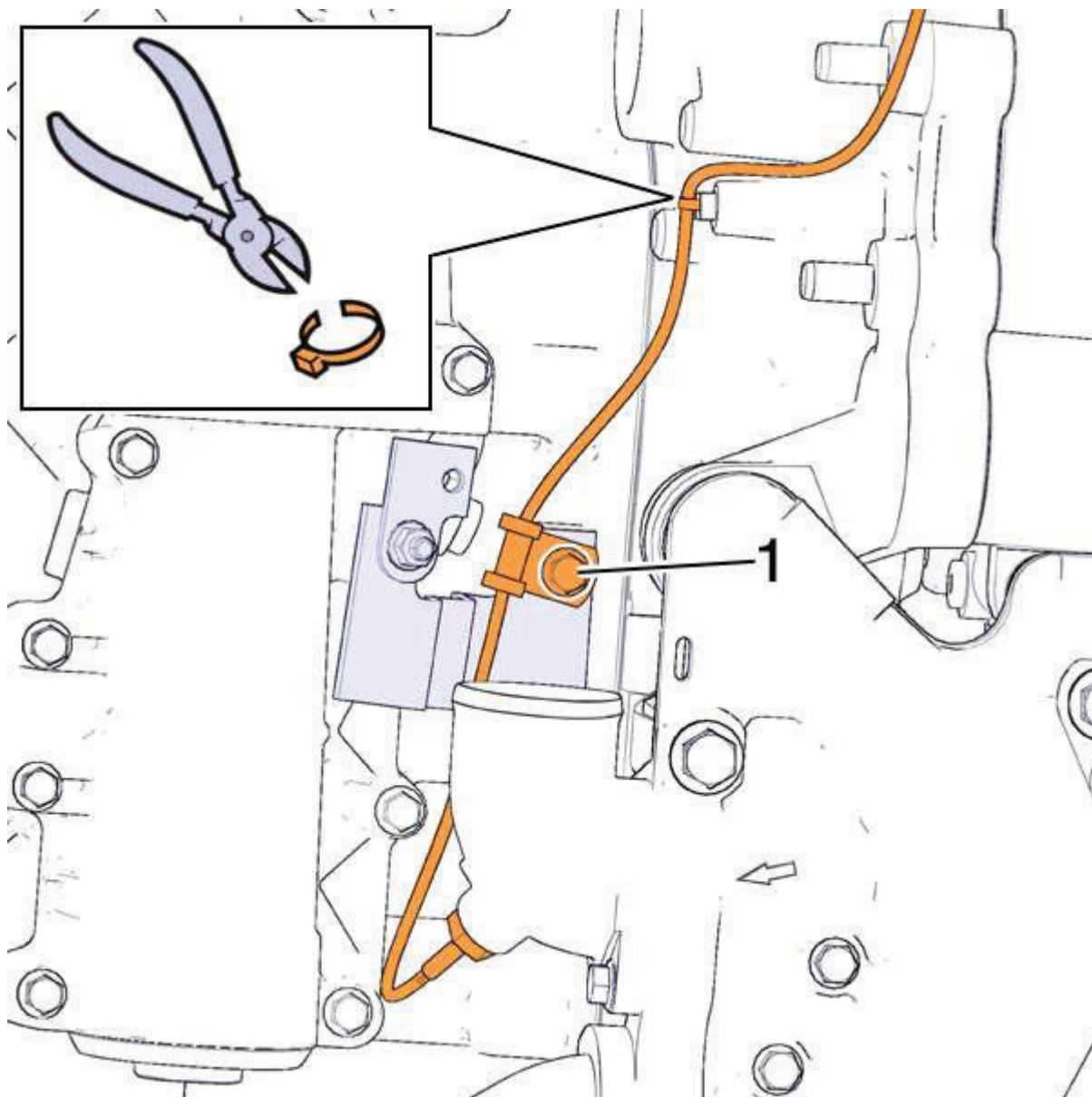

52 Remover os parafusos.

53 Remova o trocador de calor.



**Nota**

Não afrouxar o sensor.

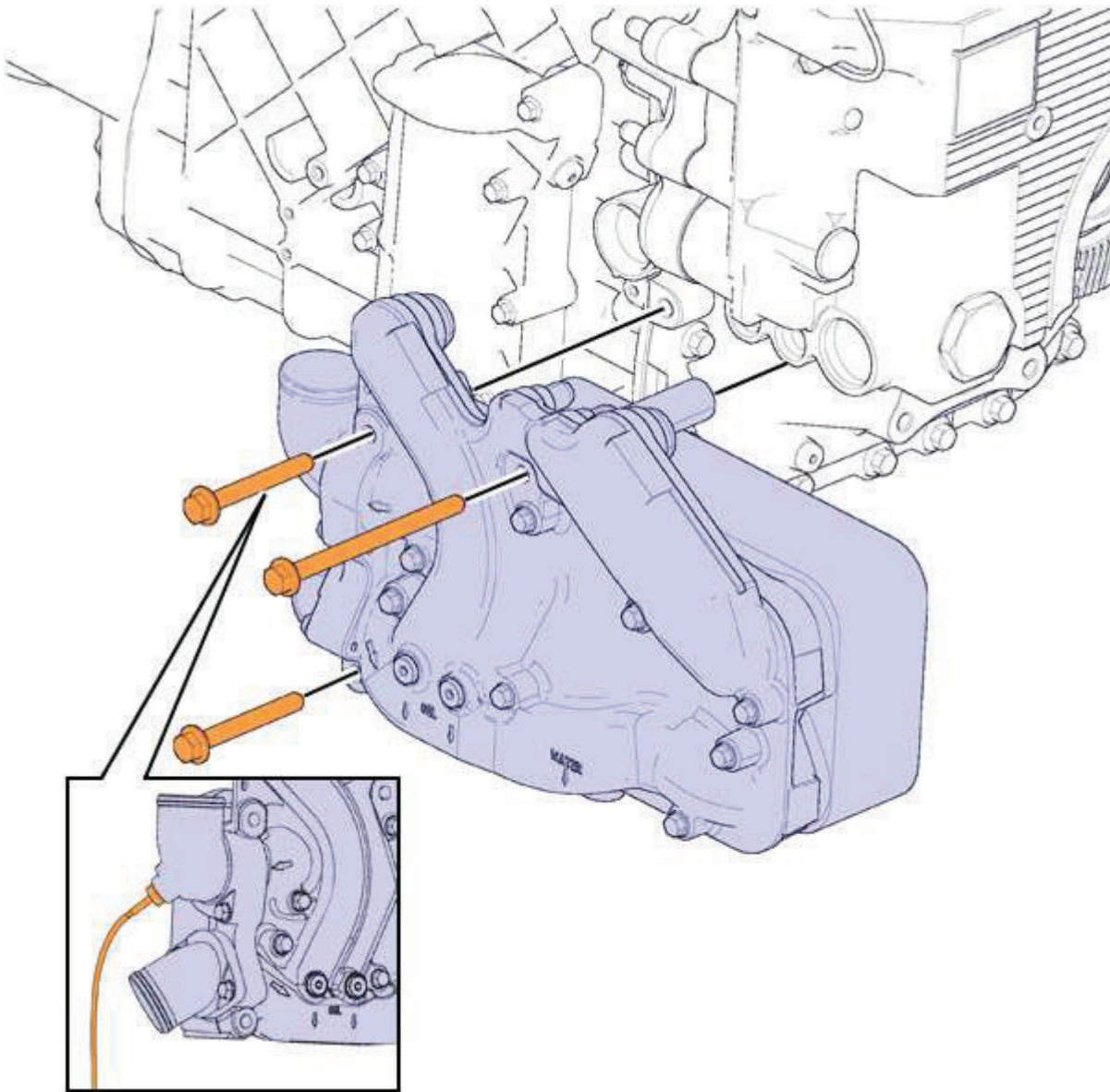

54	Remover os anéis-O.
----	---------------------

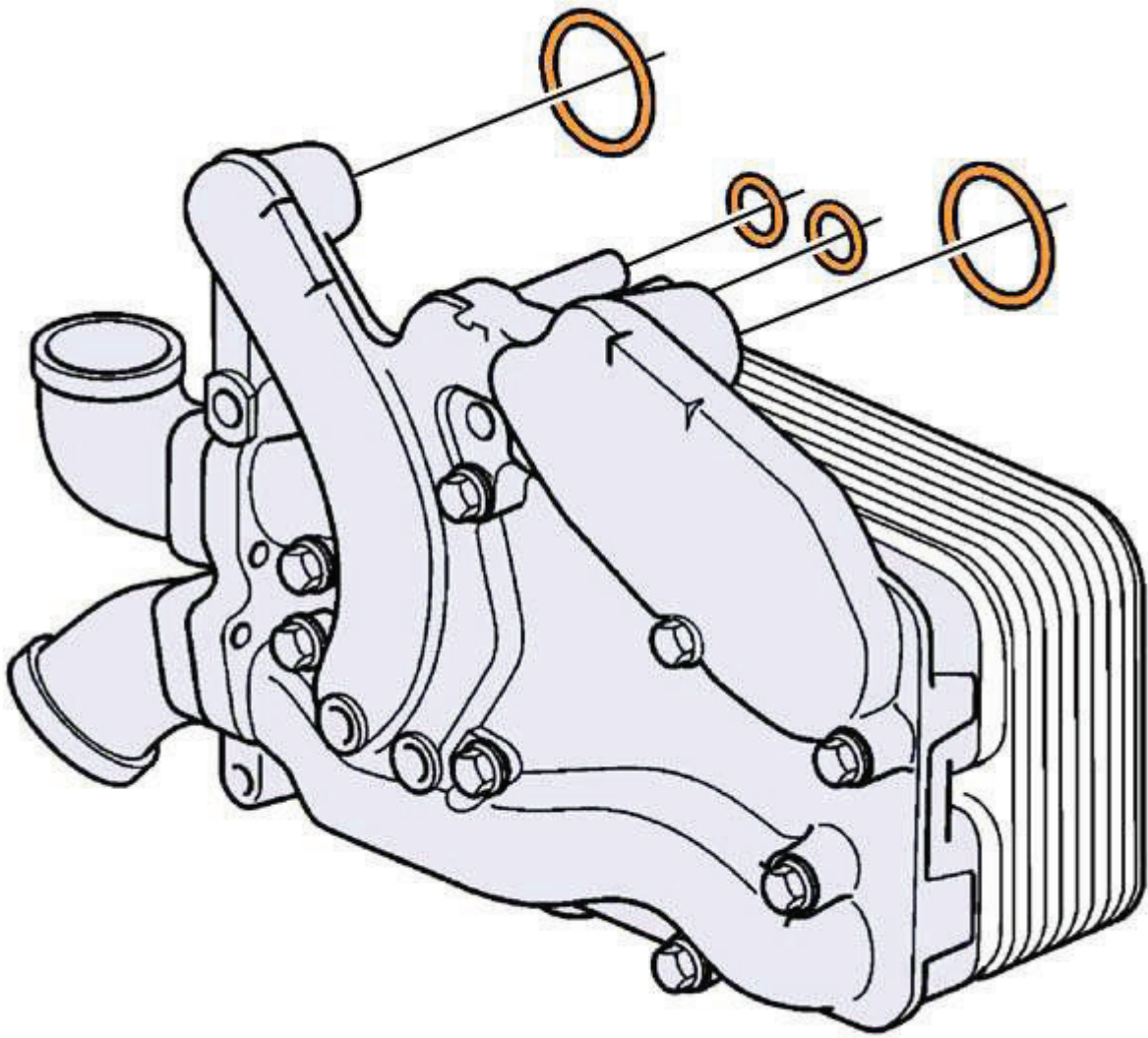

55	Girar o flange.
----	-----------------

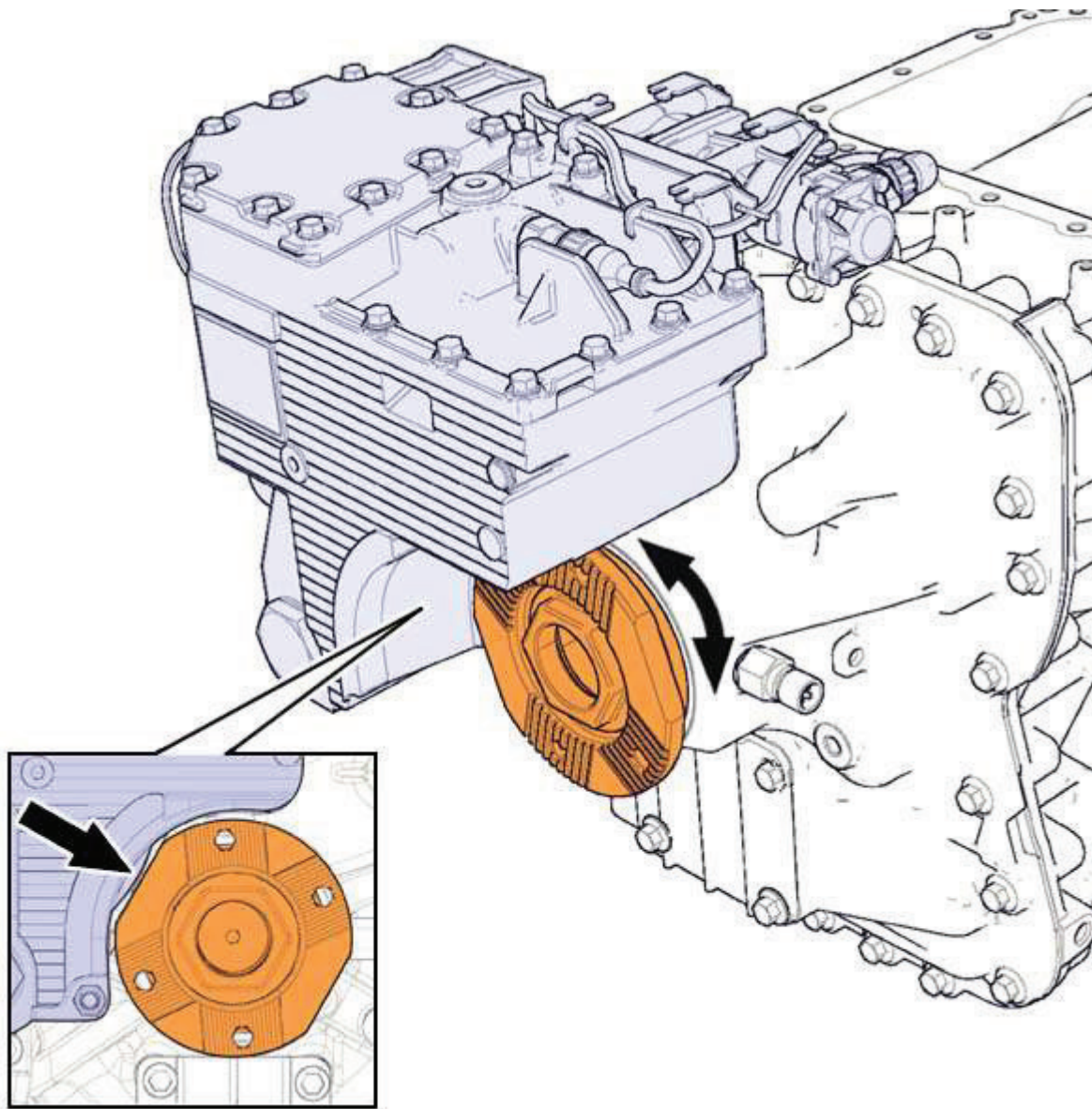

56	Posicionar a ferramenta.	
	<b>Material necessário</b>	
	dispositivo	<a href="#">[link]</a>
	carro elevador	<a href="#">[link]</a>

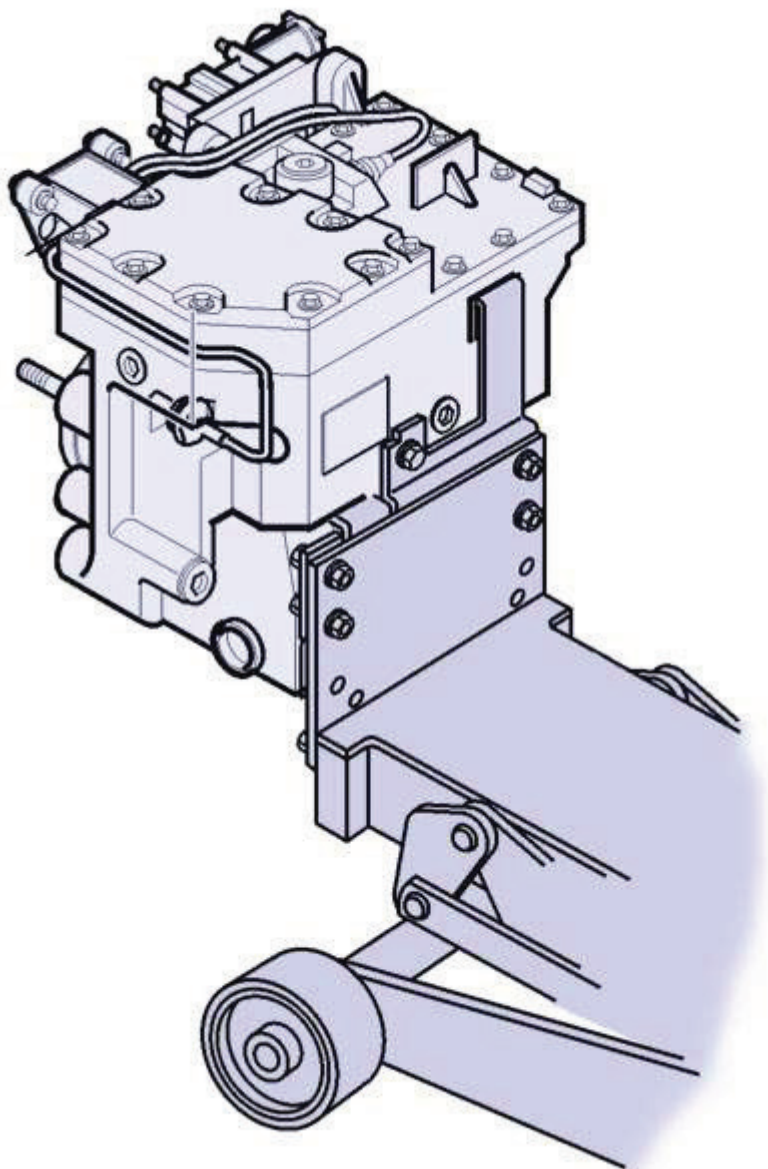

<b>57</b>	Remova as porcas (1).
-----------	-----------------------

<b>58</b>	Remover o retardador.
-----------	-----------------------

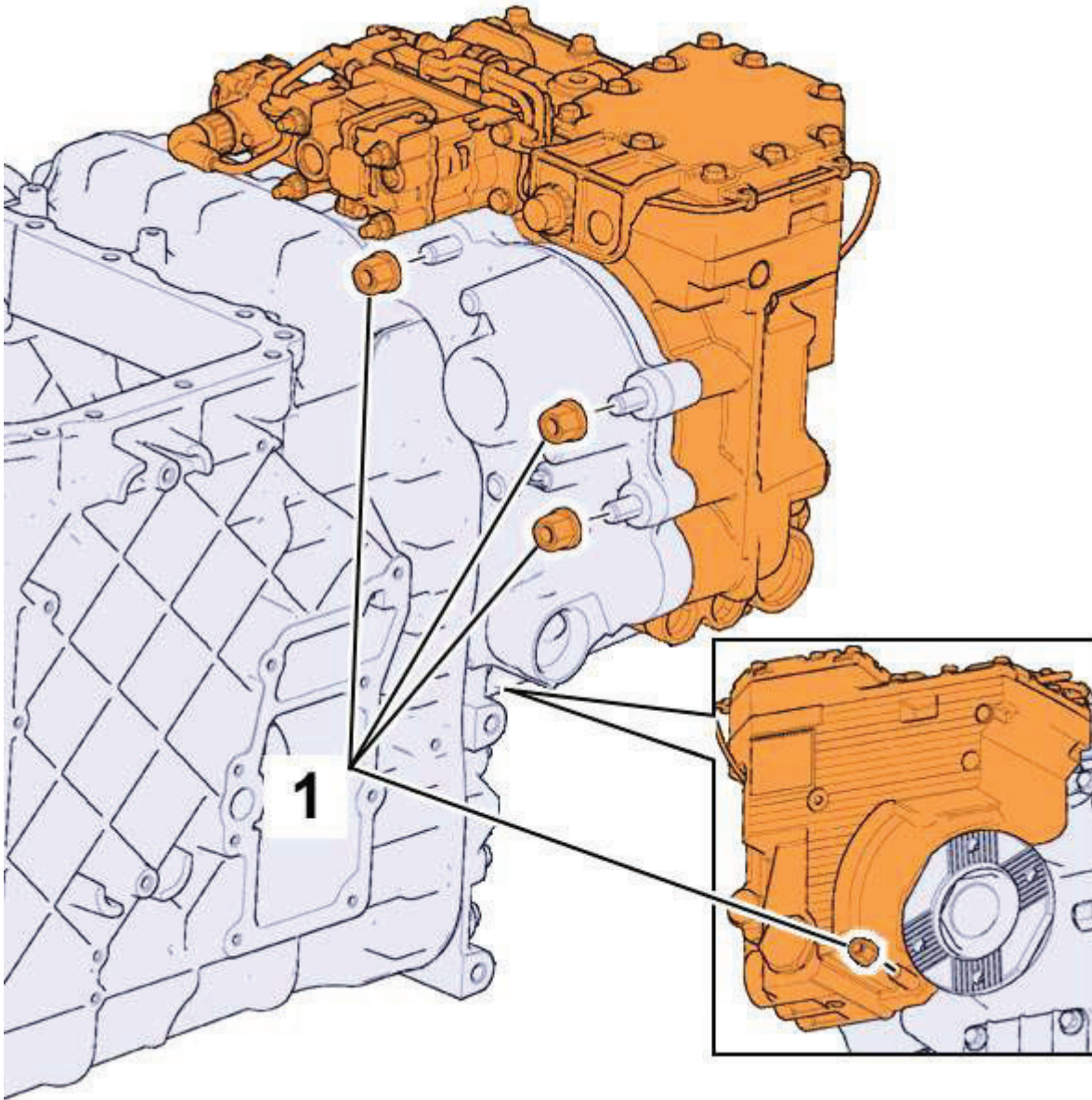

59 Remover os anéis-O.