

60	Remover o parafuso (3).		
61	Remova a mola (2).		
62	Remova a trava (1). <table border="1" data-bbox="159 1523 595 1624"><tr><td data-bbox="159 1523 231 1585"><b>i</b></td><td data-bbox="231 1523 595 1624"><b>Nota</b> Use o ímã para puxar a trava.</td></tr></table>	<b>i</b>	<b>Nota</b> Use o ímã para puxar a trava.
<b>i</b>	<b>Nota</b> Use o ímã para puxar a trava.		

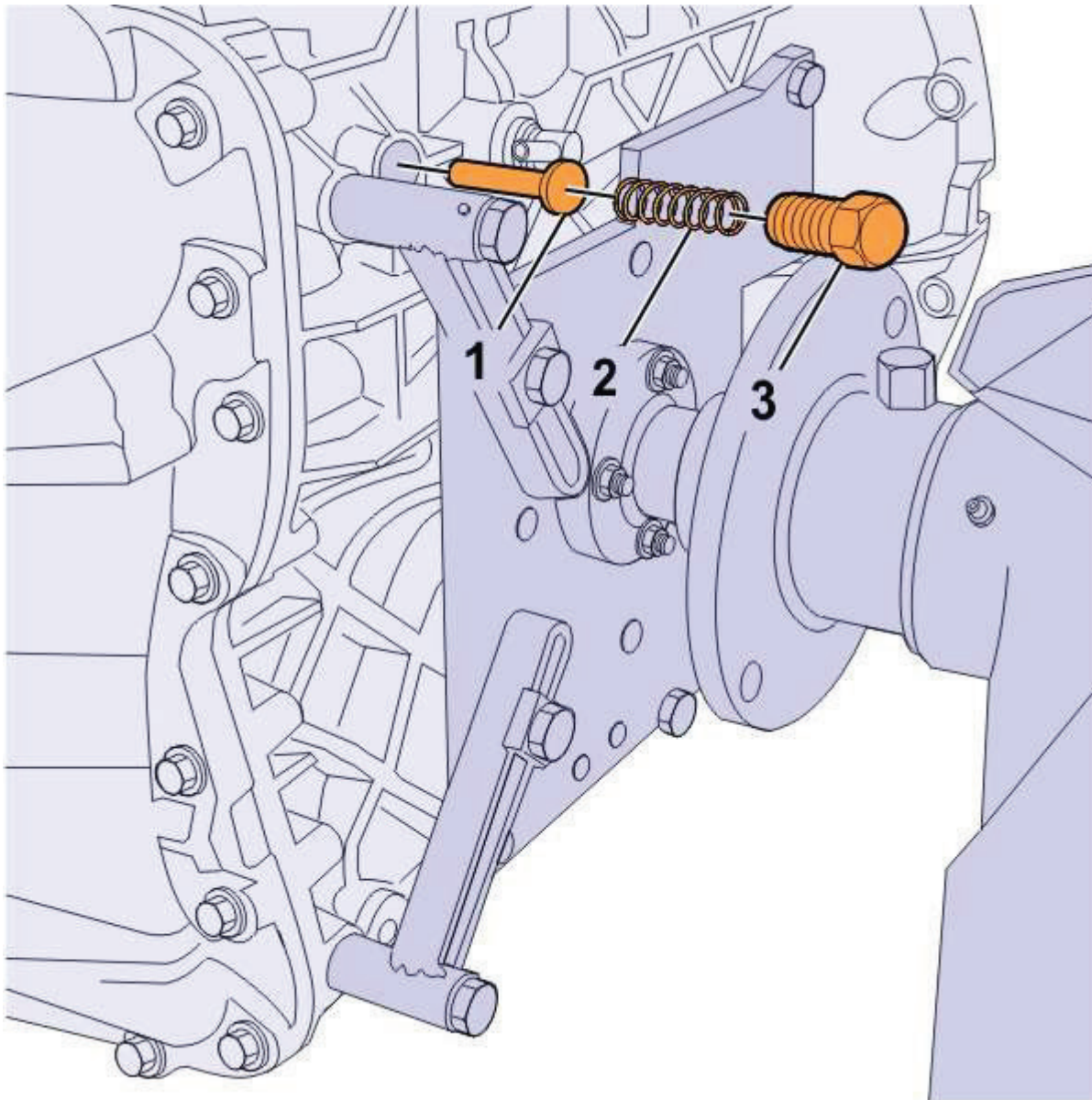

Com tomada de força.

63	Remover o anel trava.
----	-----------------------

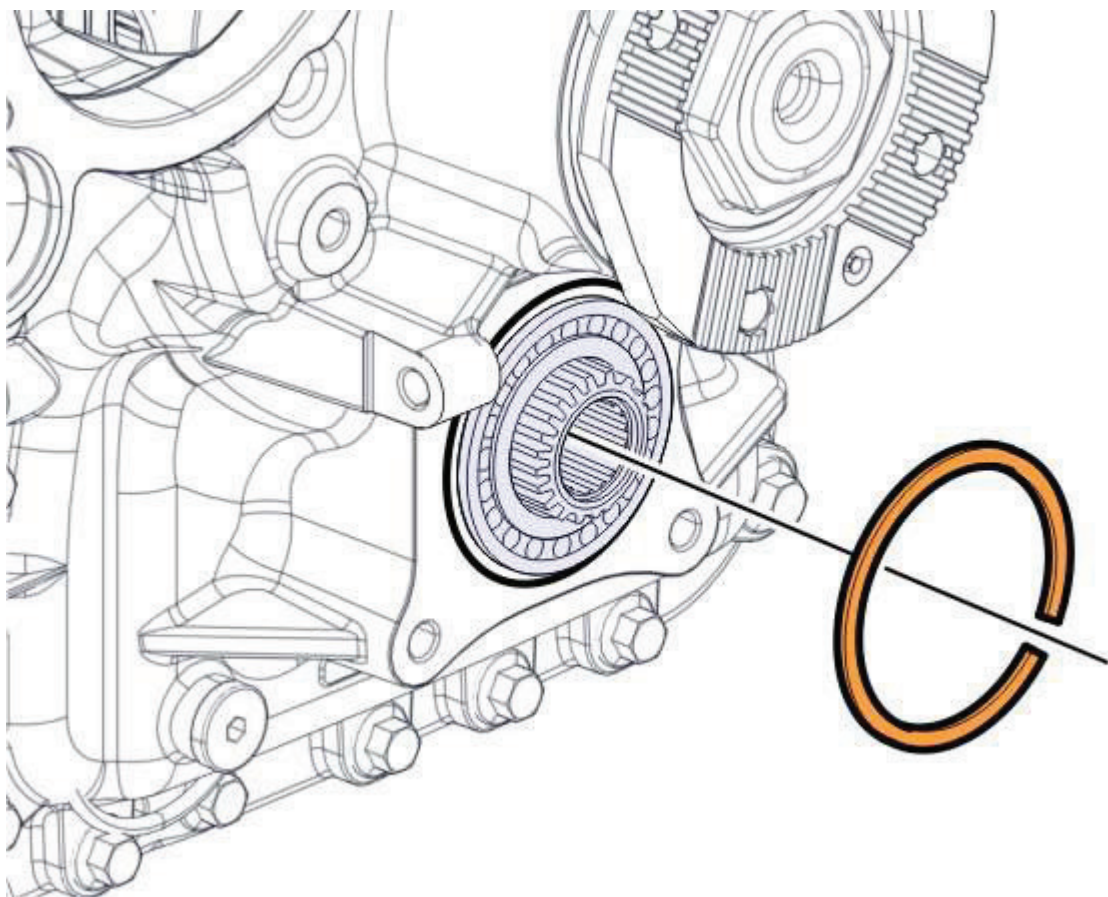

64 Remover o eixo junto com o rolamento.

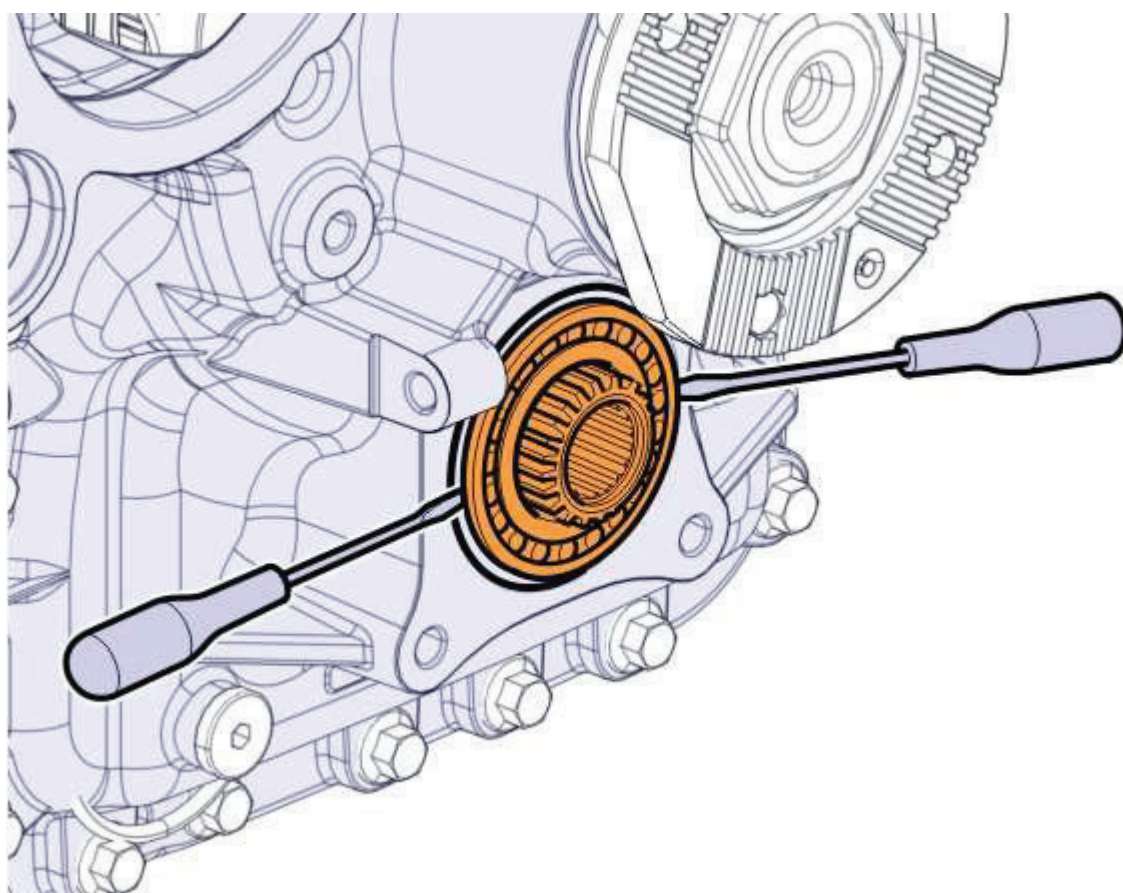

65 Remover o eixo.

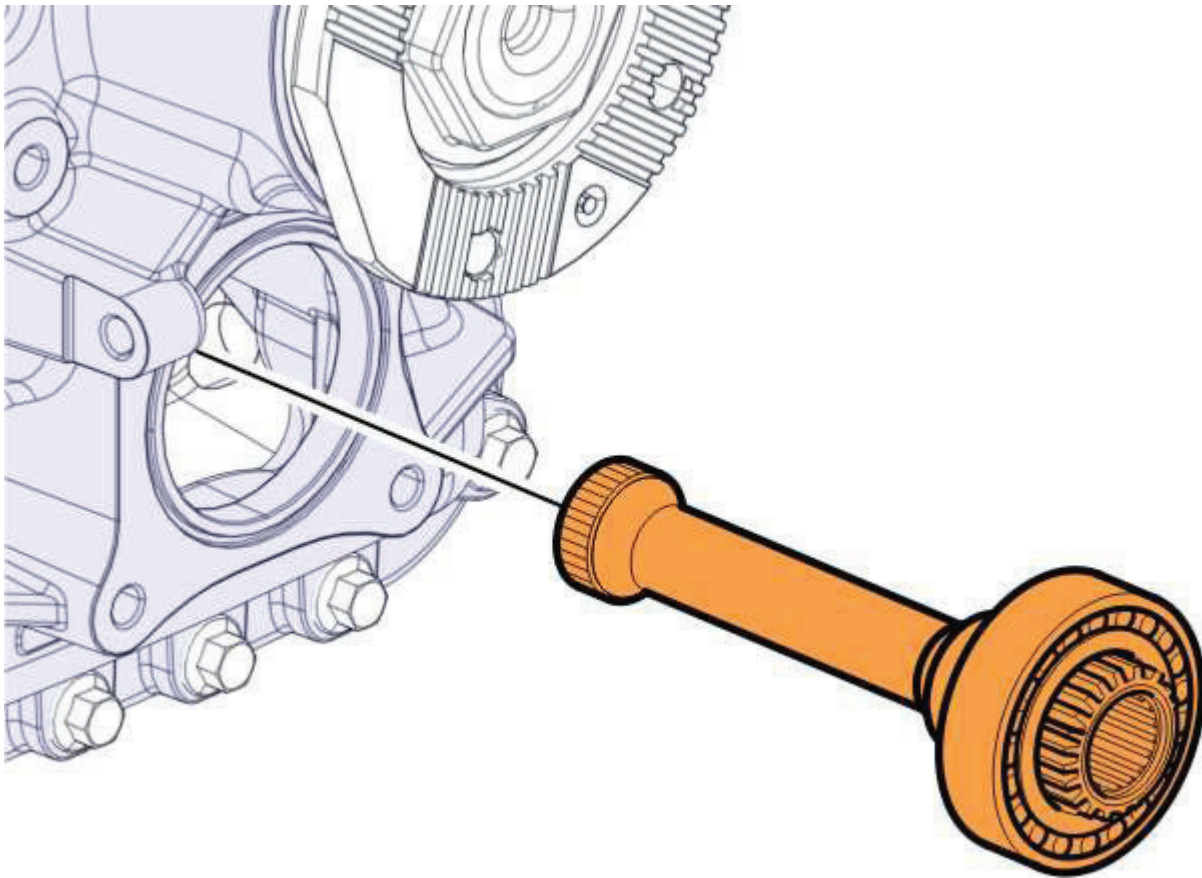

66 Remover os parafusos.

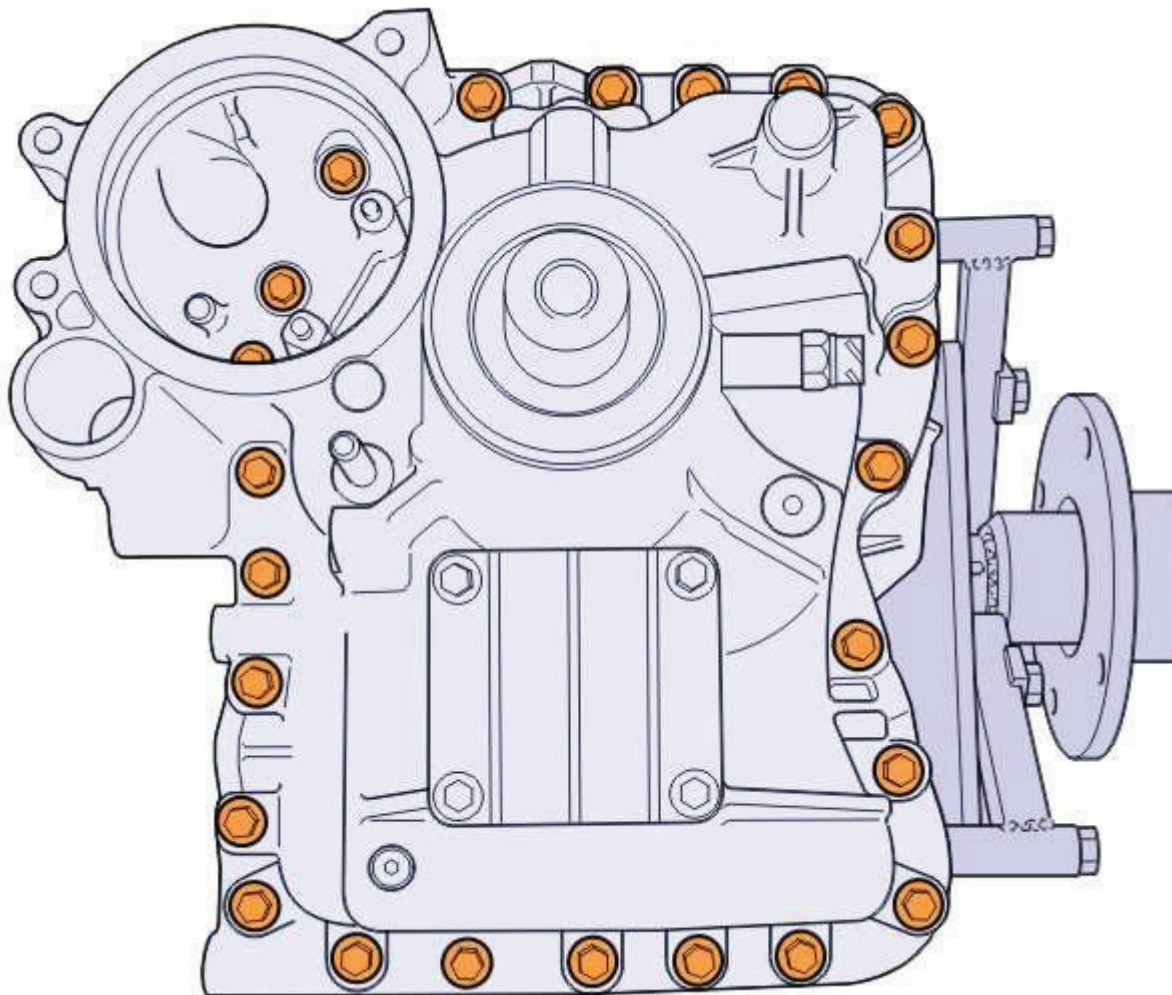

67	Remove o alojamento.	
	<b>Material necessário</b>	
	ADAPTADOR	_____
	ARGOLA DE ELEVAÇÃO	_____
	PRENSA	_____

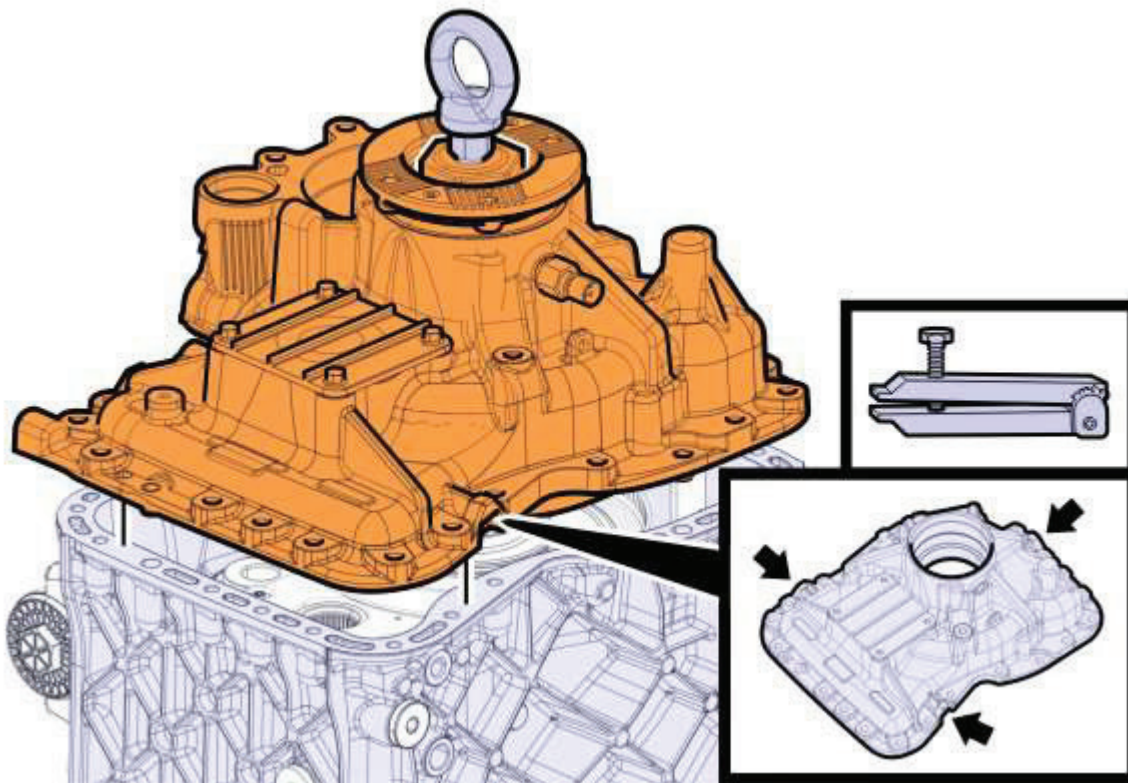

68	Remover o tubo.
<b>Material necessário</b>	
soquete	_____

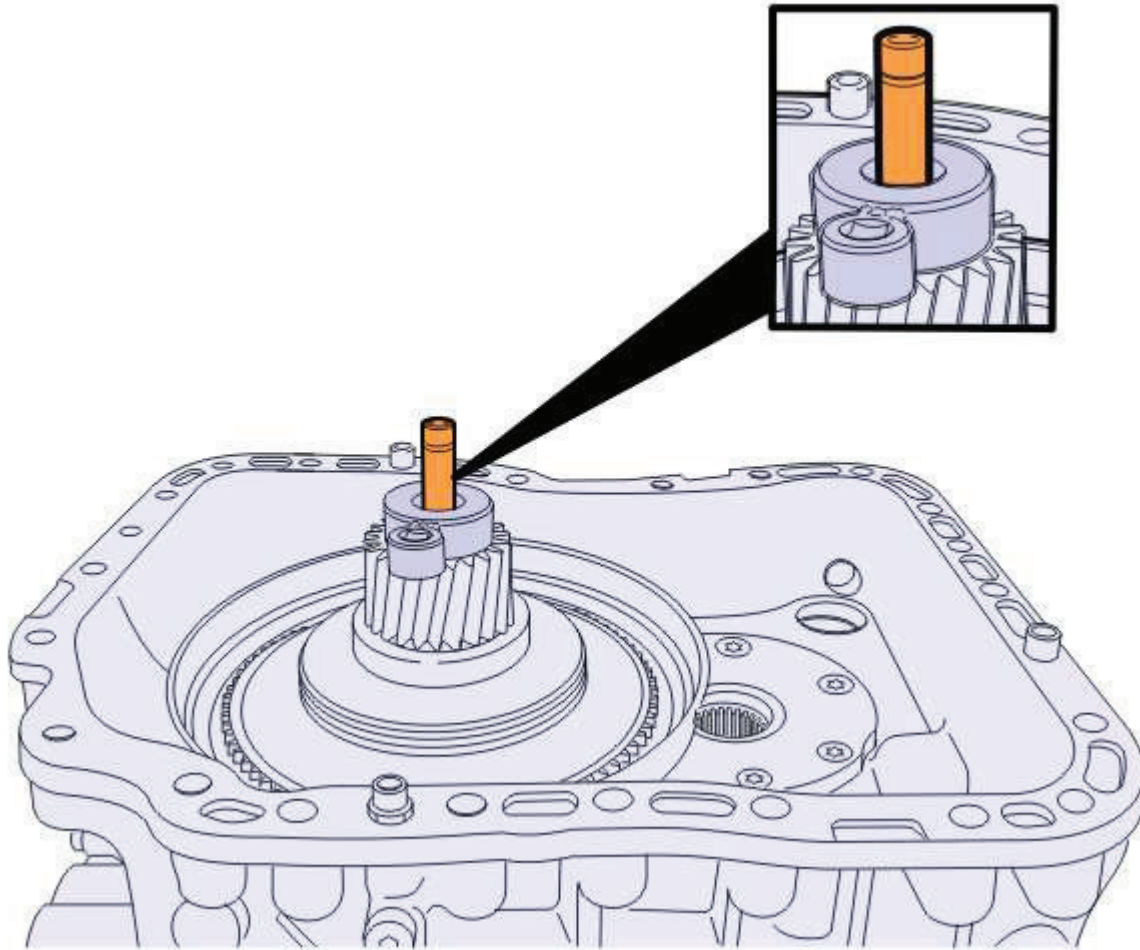

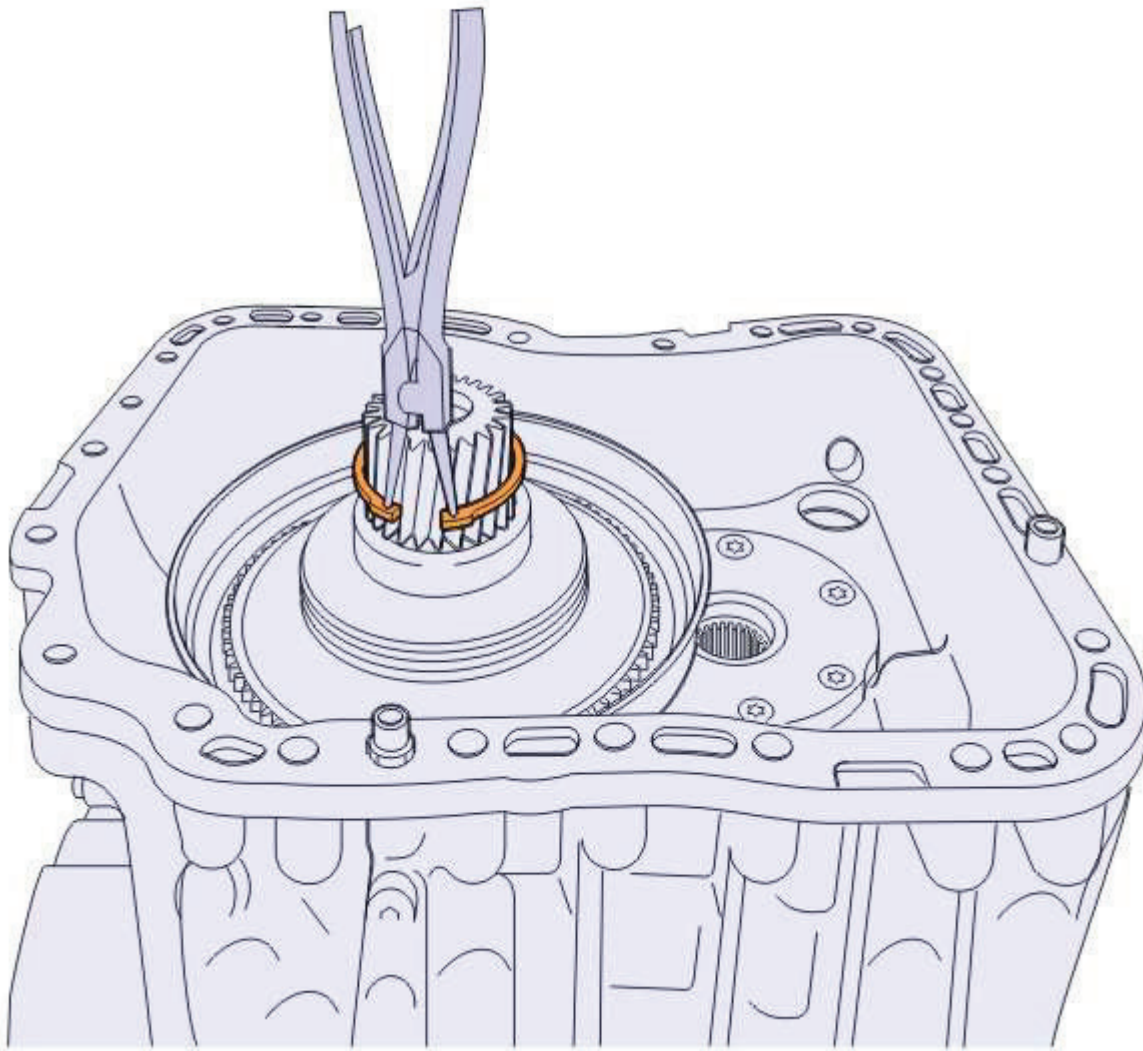

69	Remover o grampo circular.
----	----------------------------



70 Remover as metades do anel trava.

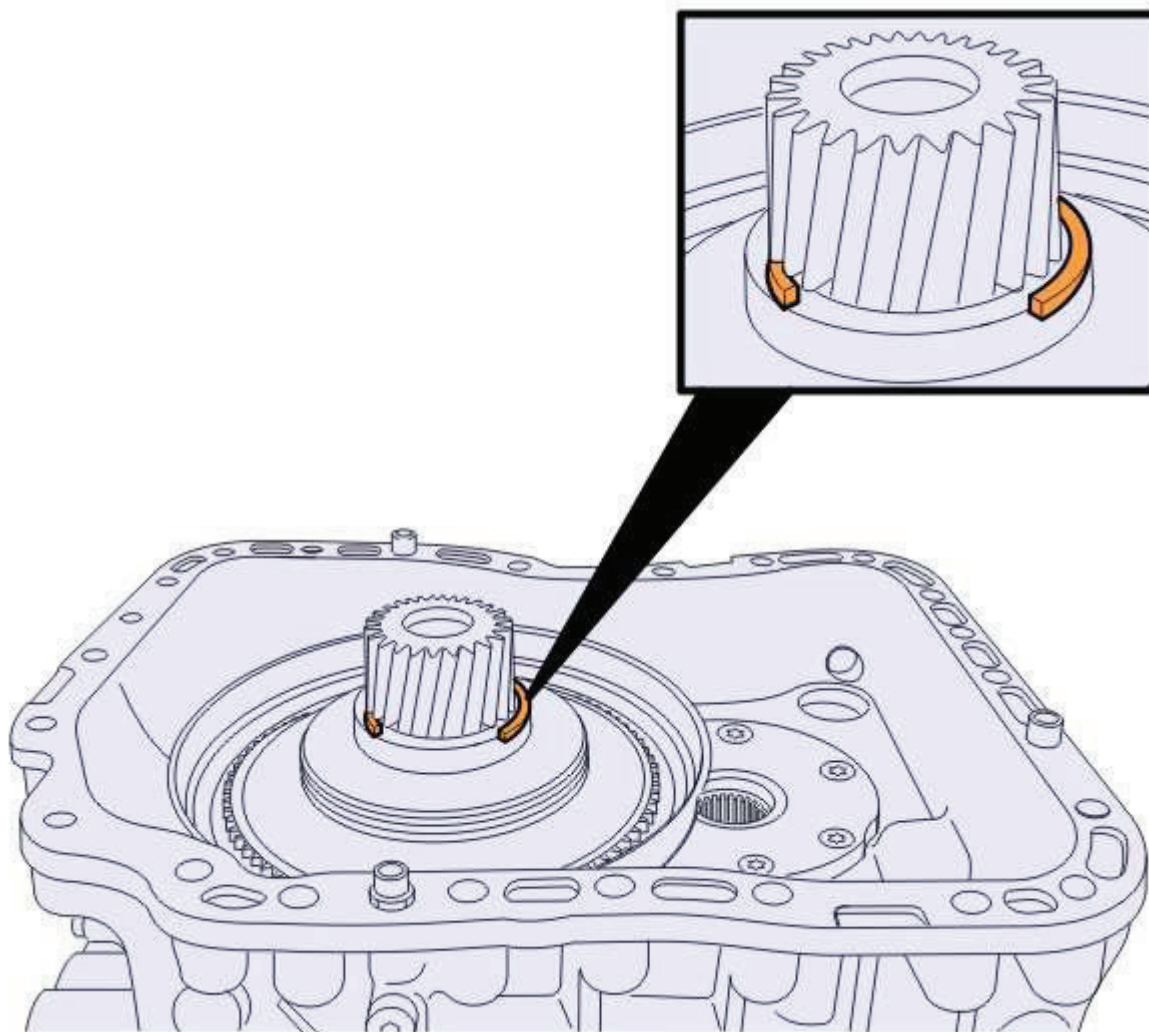



71	Instalar as ferramentas.
<b>Material necessário</b>	
sacador	_____
mandril	_____
sacador	_____
cilindro hidráulico	_____
PONTA DE EIXO	_____
BOMBA HIDRÁULICA	_____
	<b>Nota</b>
	Certifique-se de que a marcação de divisão na ferramenta (D) esteja em 90° em para dividir na ferramenta (C).

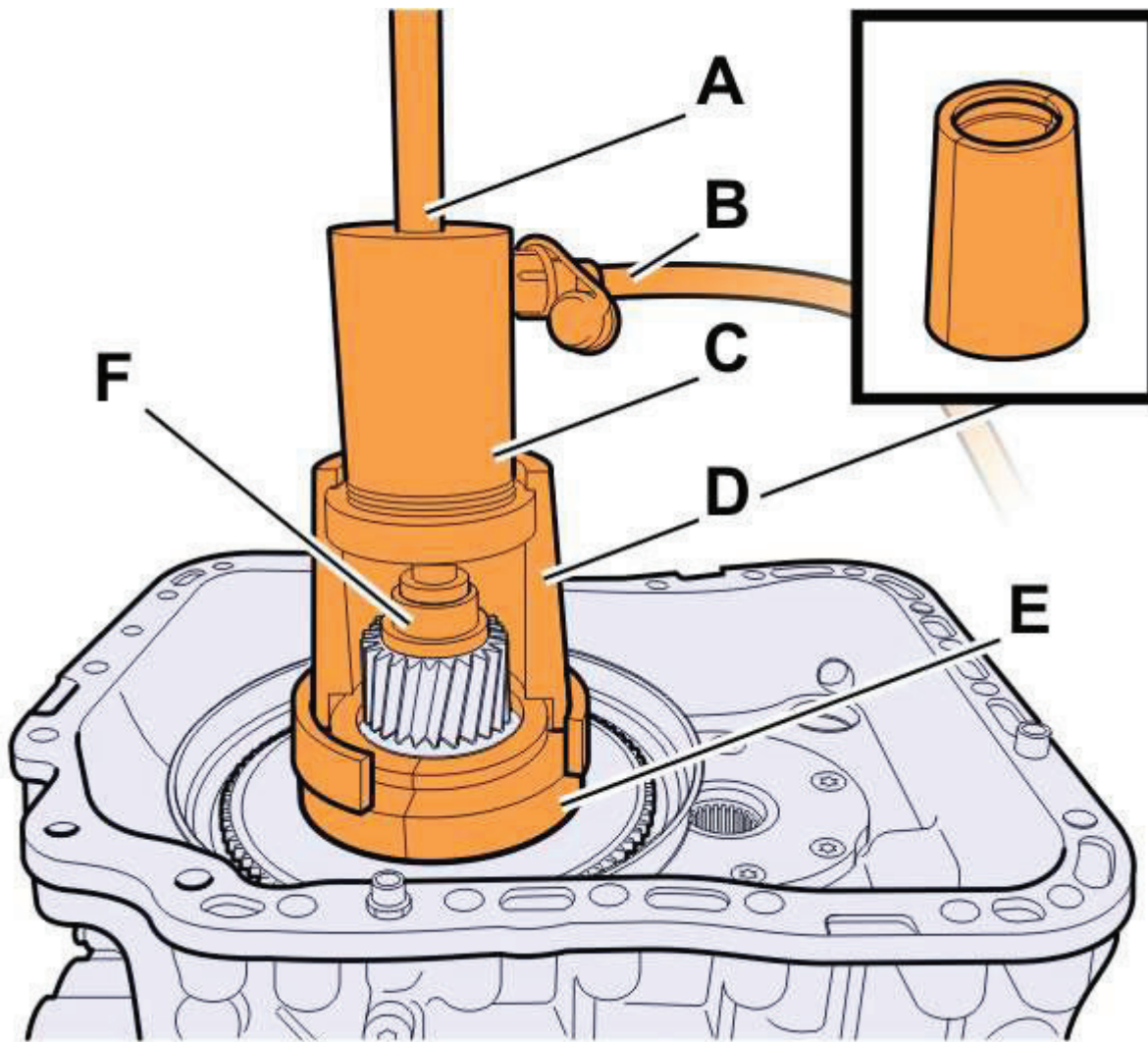

A	<u>PONTA DE EIXO</u>
B	<u>BOMBA HIDRÁULICA</u>
C	<u>cilindro hidráulico</u>
D	<u>sacador</u>
E	<u>sacador</u>
F	<u>mandril</u>

72	Remover o cone de faixa.
----	--------------------------

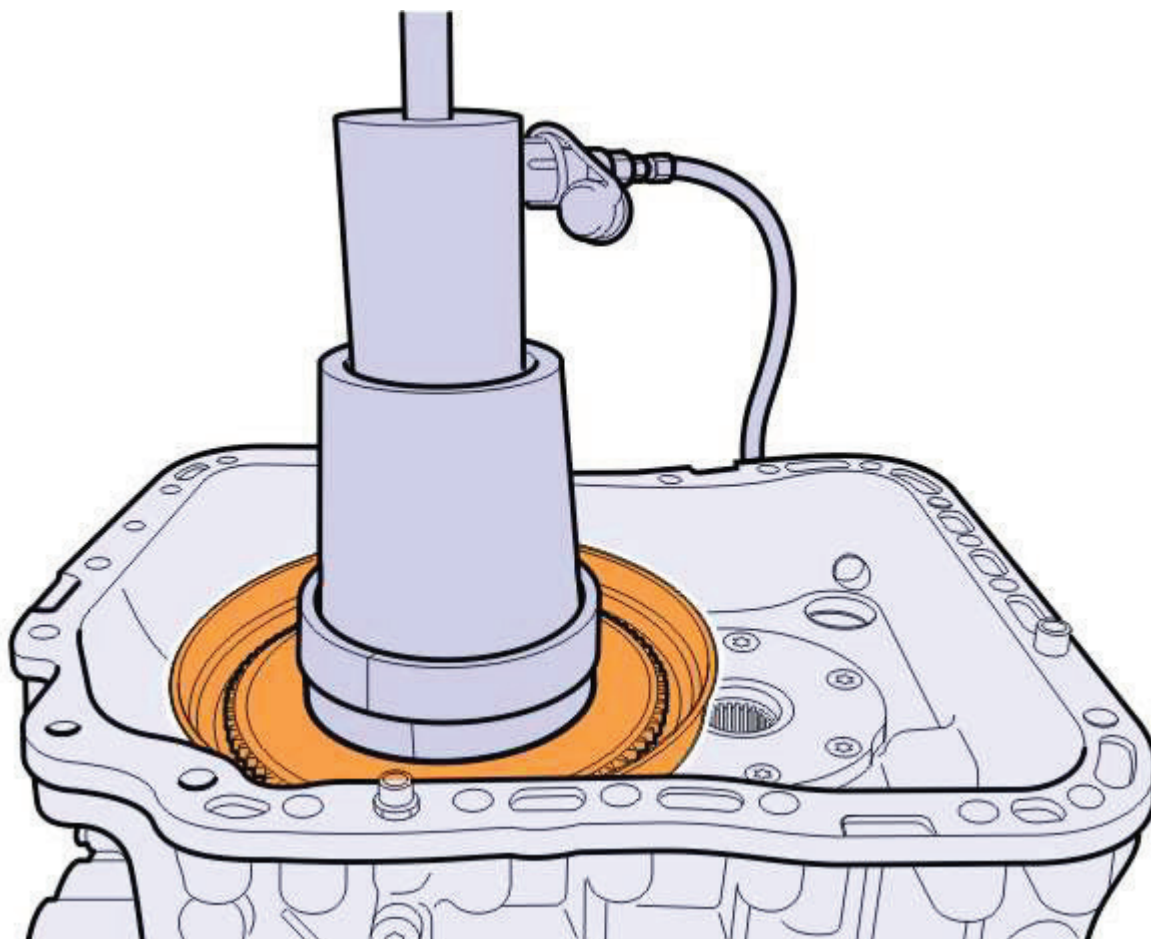

73 Remover o parafuso.

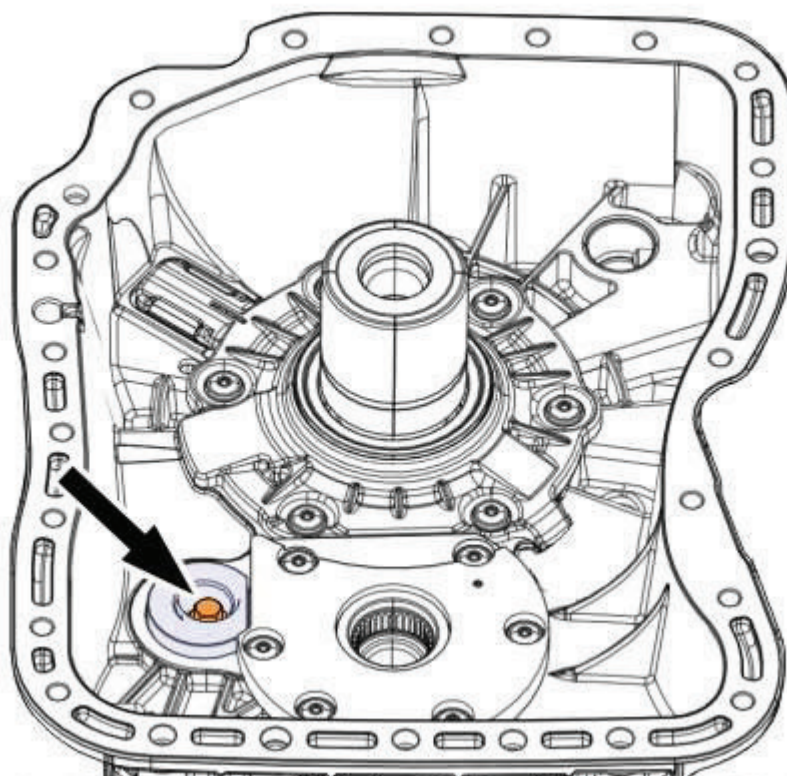



74 Remover os parafusos.

75 Remover a tampa.

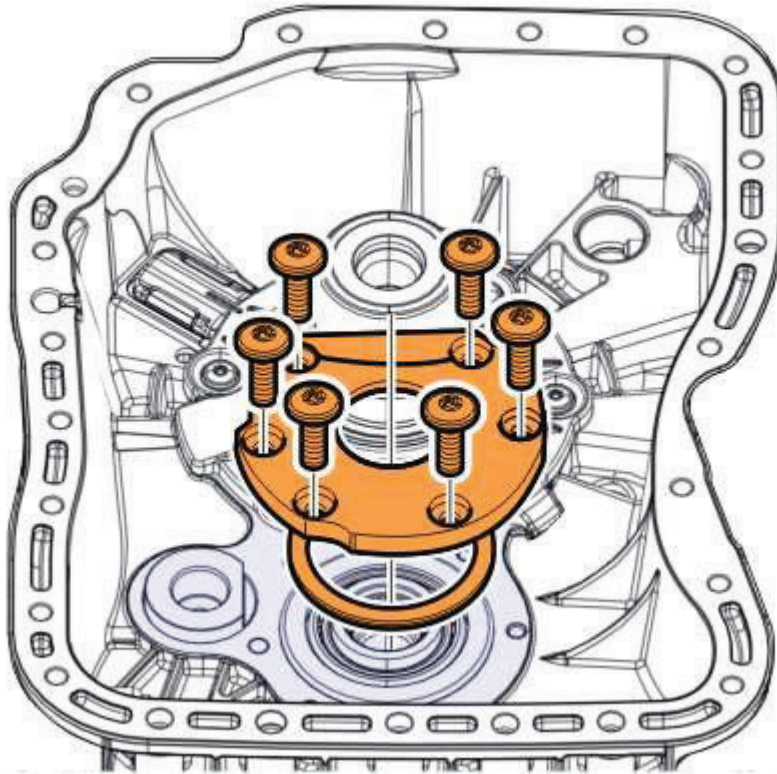
76 Remover o calço.



77	Instalar as ferramentas.	
	<b>Material necessário</b>	
	PONTA DE EIXO	
	SCREW	

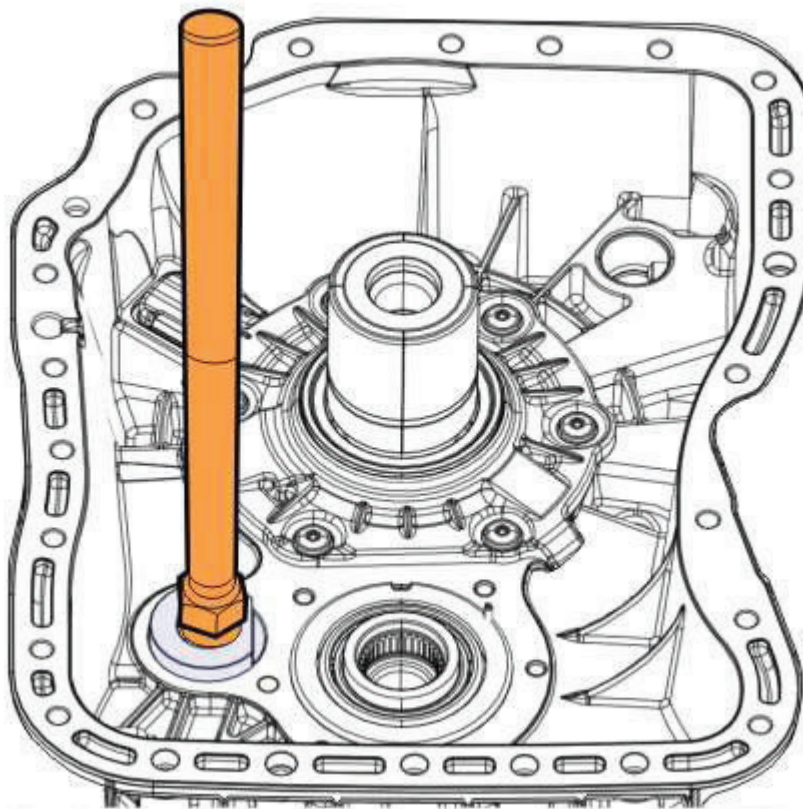

<b>78</b>	Instalar as ferramentas.	
	<b>Material necessário</b>	
	cilindro hidráulico	_____
	mandril	_____
	BOMBA HIDRÁULICA	_____

<b>79</b>	Remover o eixo da marcha à ré.
-----------	--------------------------------

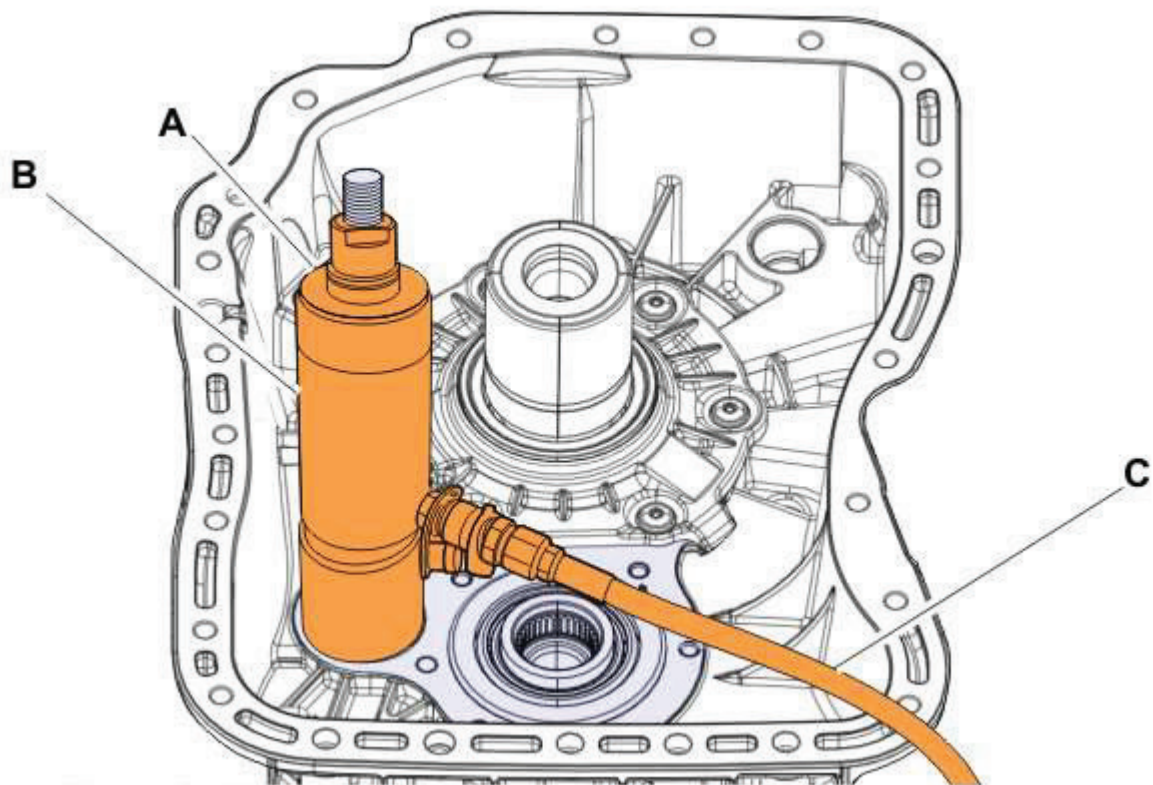

A	<u>cilindro hidráulico</u>
B	<u>mandril</u>
C	<u>BOMBA HIDRÁULICA</u>

<b>80</b>	Remover a bomba de óleo junto com o pinhão da engrenagem de marcha à ré.
-----------	--

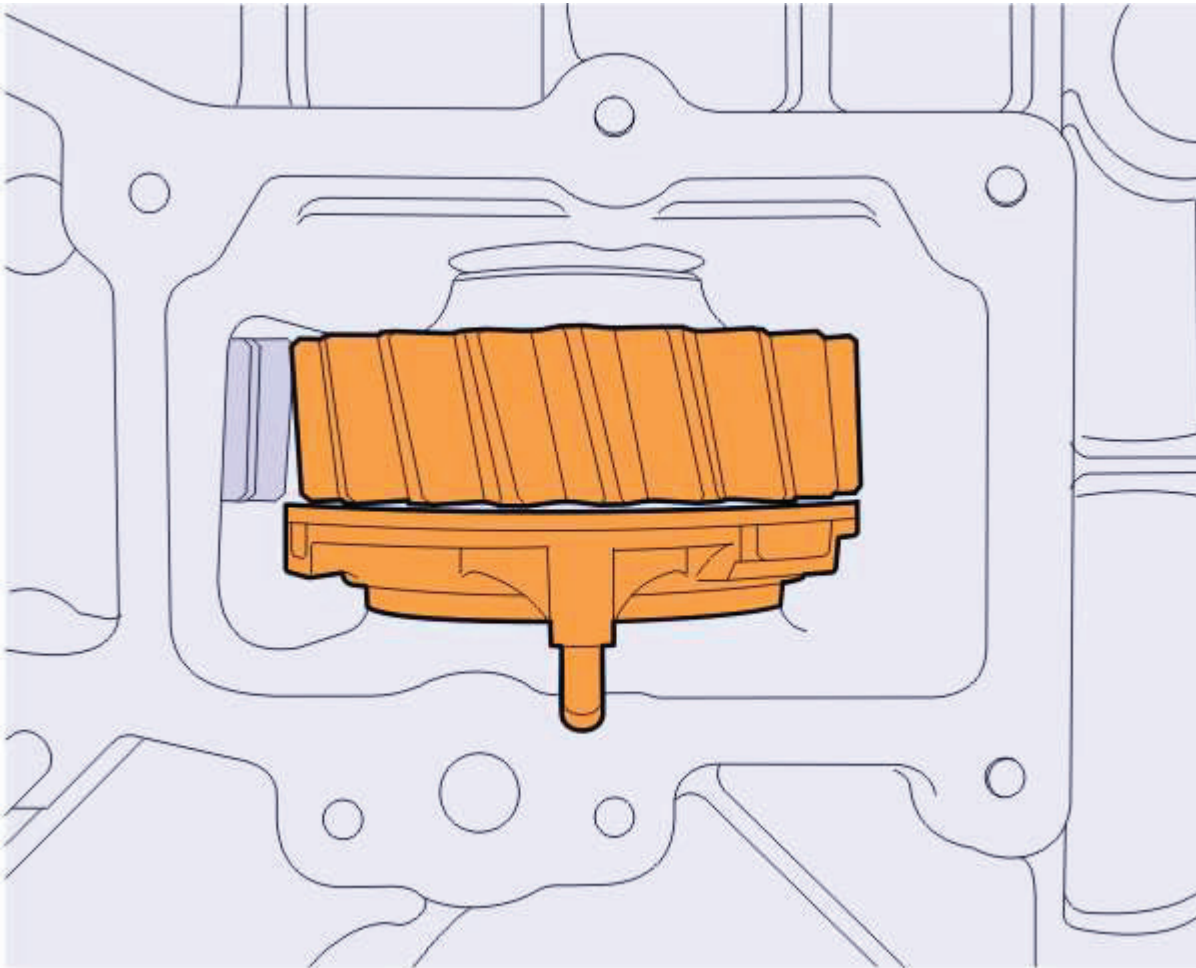

81 Desmontar as peças.

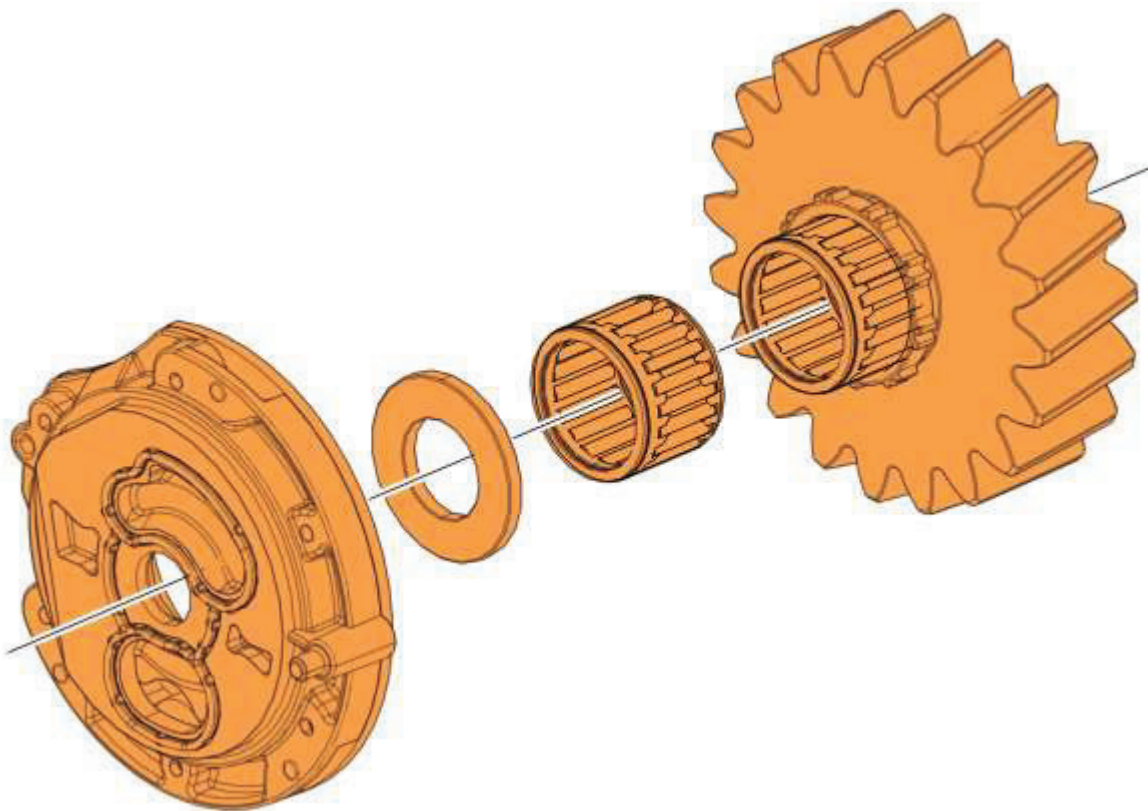

82 Remova a junta.

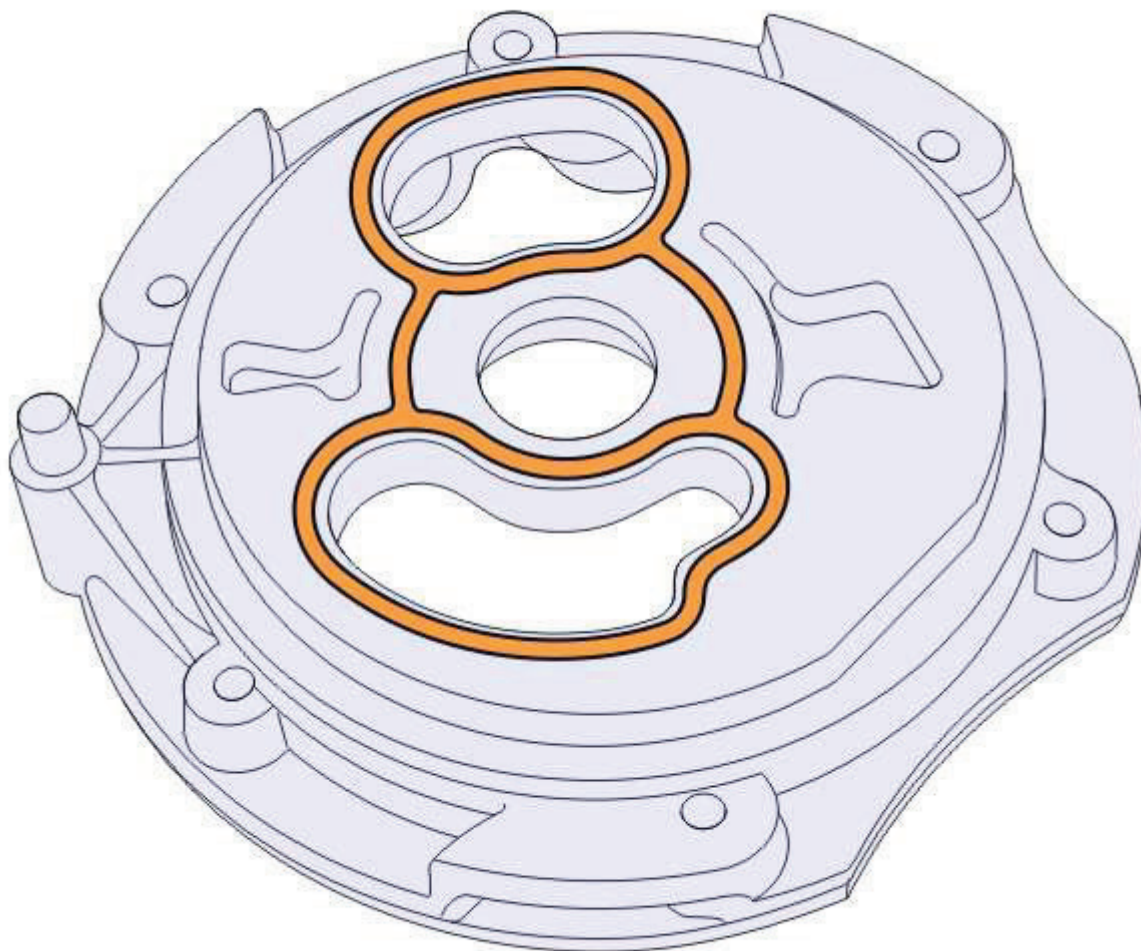

83	Remova os parafusos.
----	----------------------



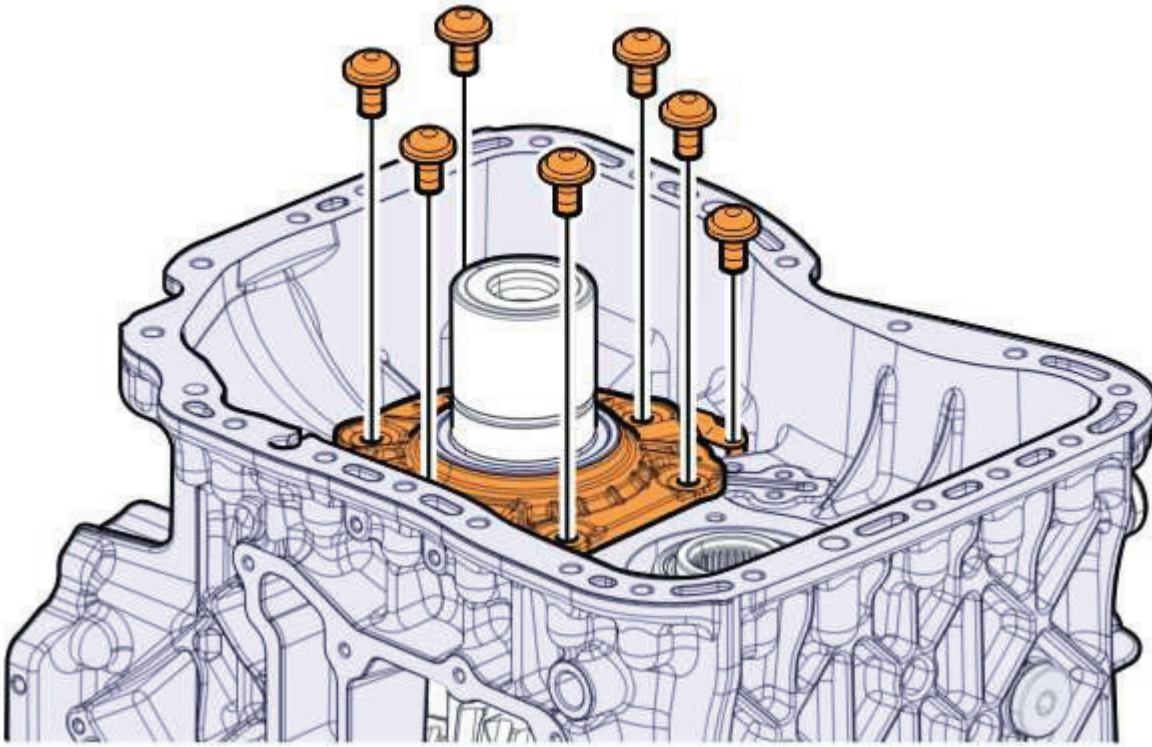

84	Remover a tampa juntamente com o tubo.
----	--

85	Remova o calço de ajuste.
----	---------------------------

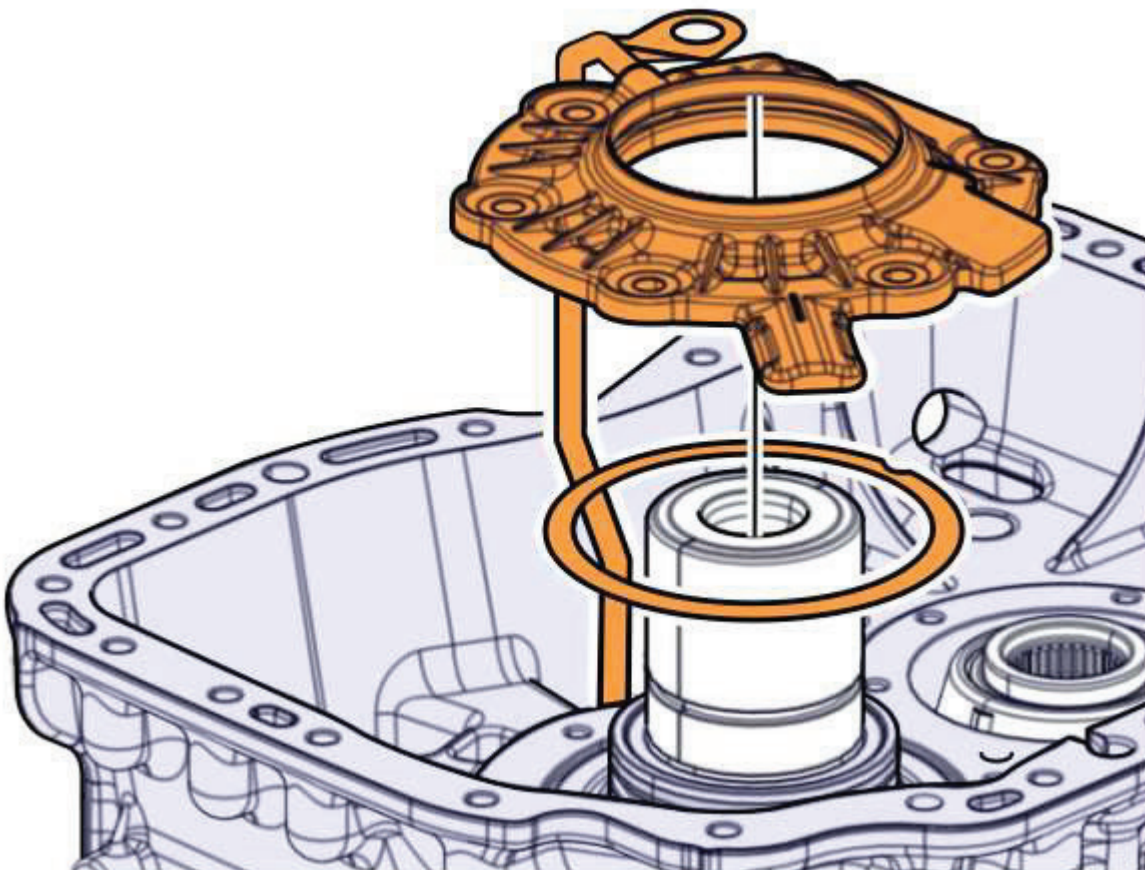

86	Execute este procedimento quando a condição abaixo for atendida.
----	--

### Condições

- Se as pistas externas estiverem frouxas.

OU

- Se as pistas puderem ser giradas.

- ▶ Substitua o alojamento básico.

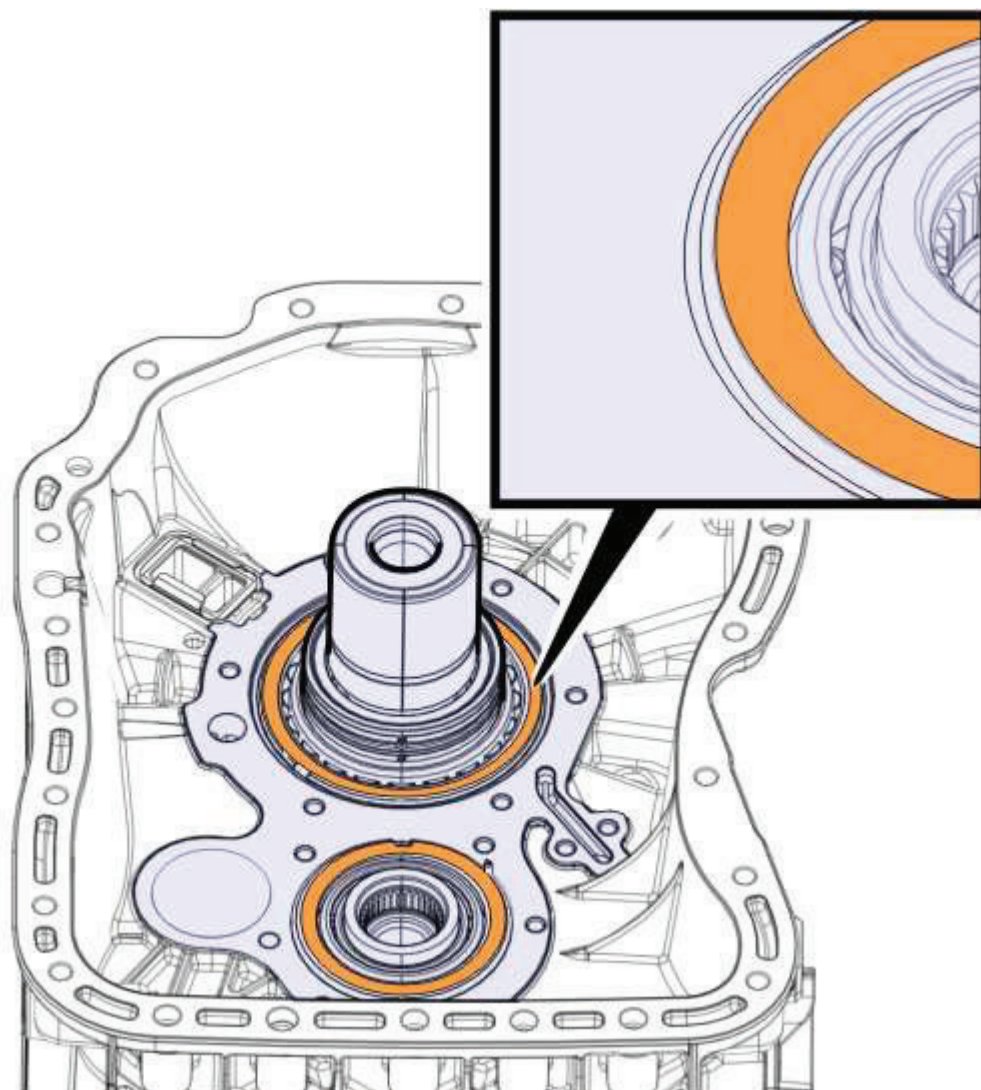

**87** Remover o tubo.

**88** Remover os parafusos.

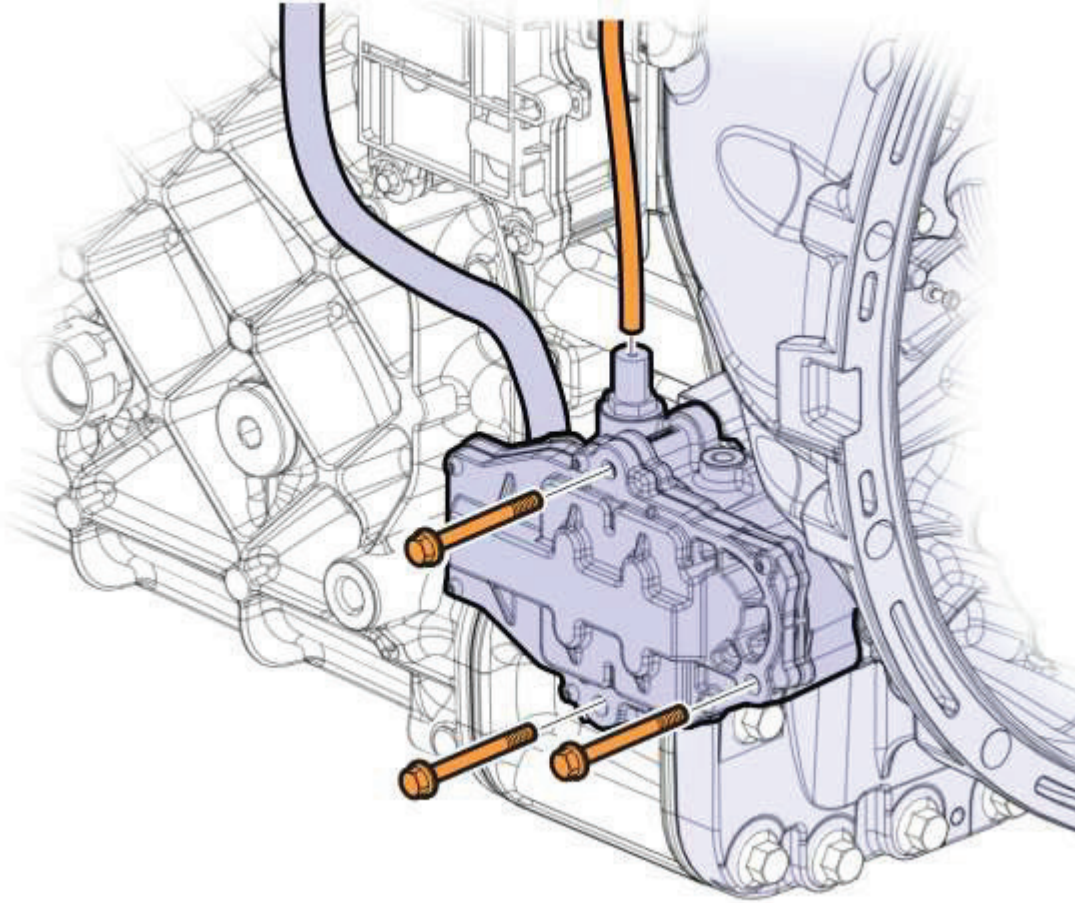

89	Remover a válvula.
----	--------------------

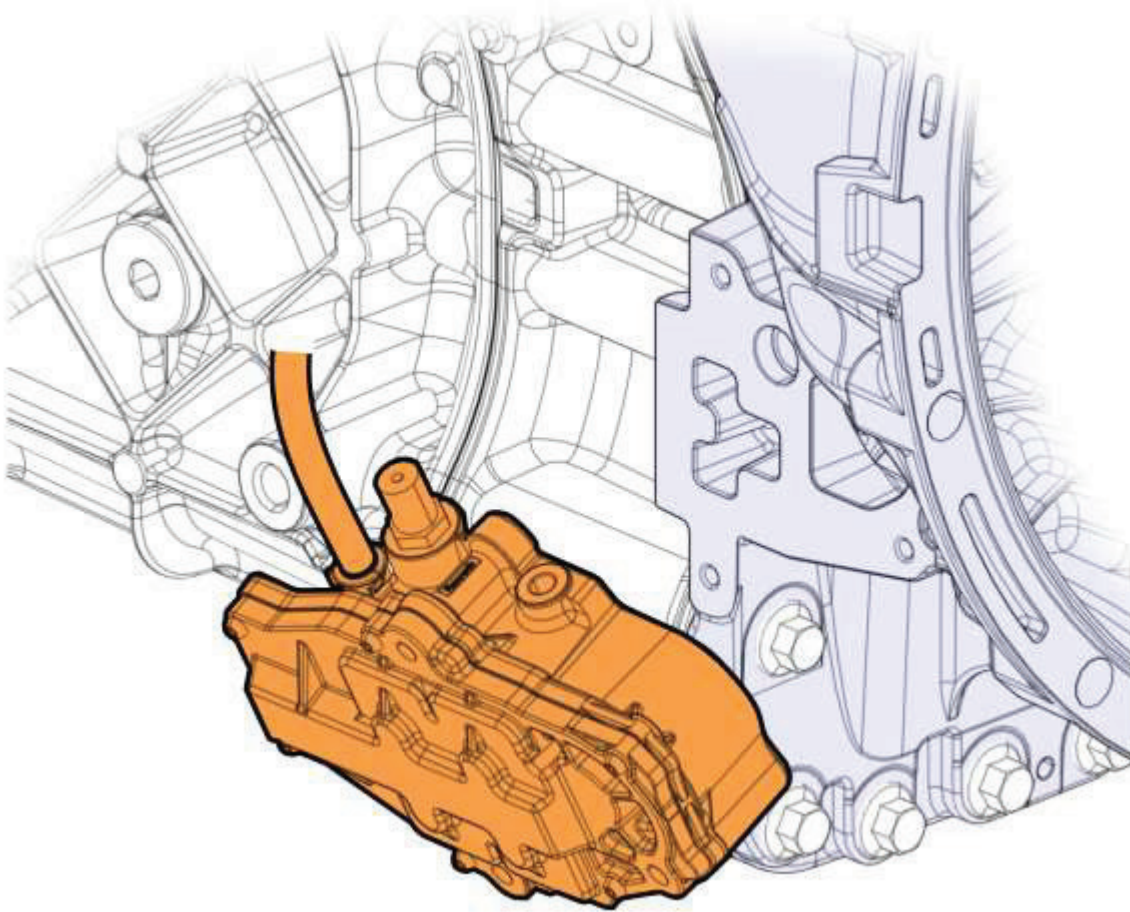

90	Remover as braçadeiras.
----	-------------------------

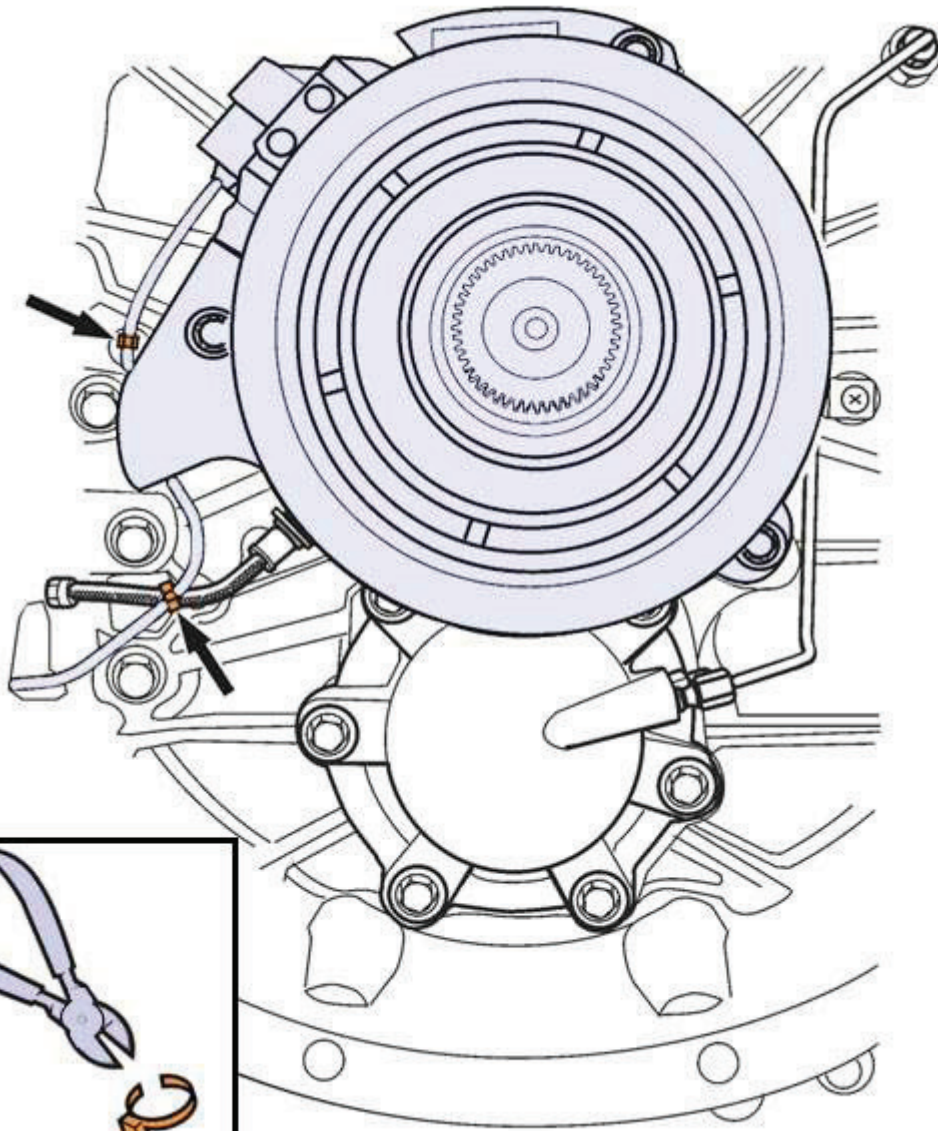

91	Desconectar o conector.
----	-------------------------

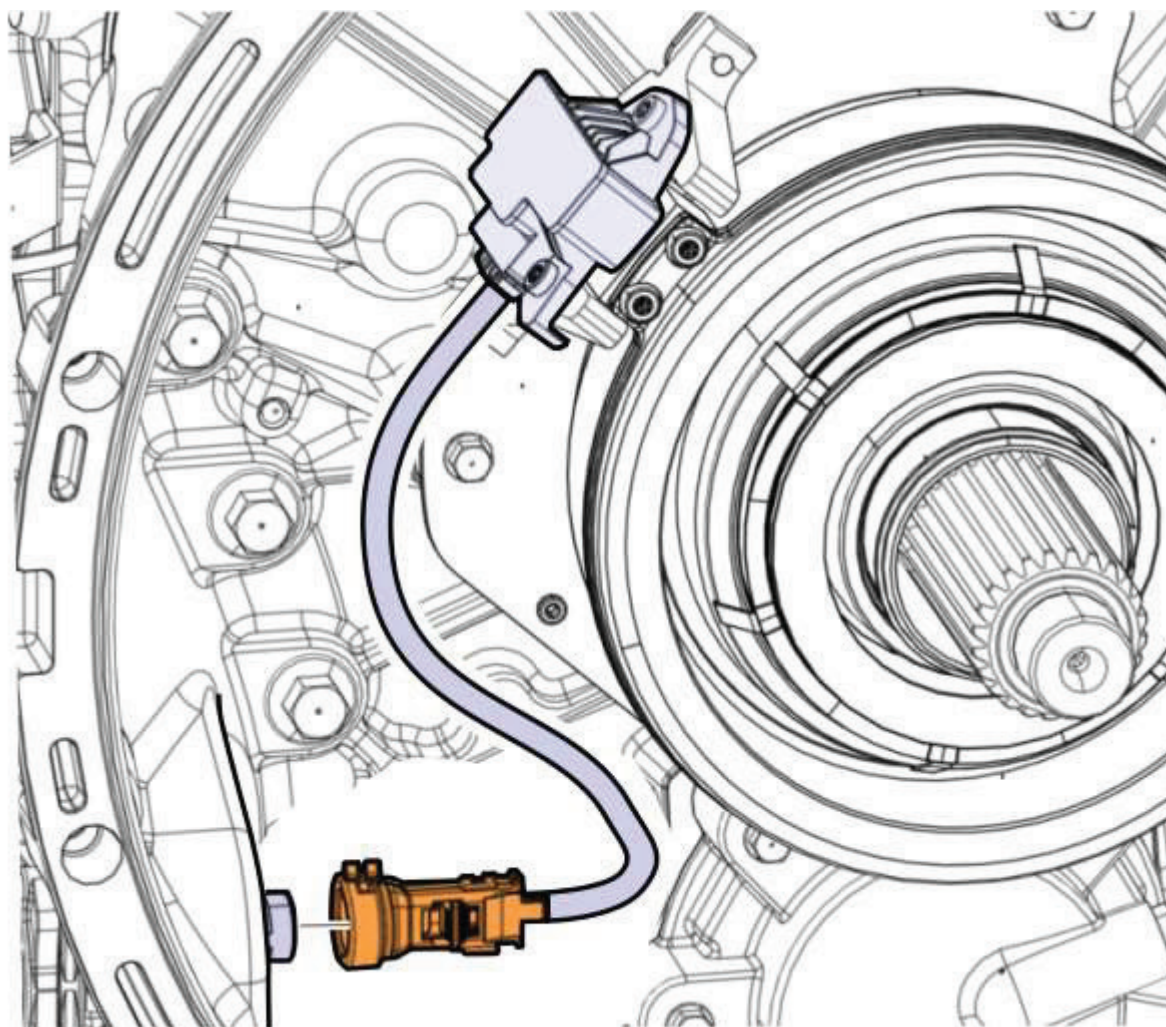

<b>92</b>	Remover o grampo.
-----------	-------------------

<b>93</b>	Remover a mangueira.
-----------	----------------------