

► Remova a pista externa.

**Material necessário**

manípulo



mandril



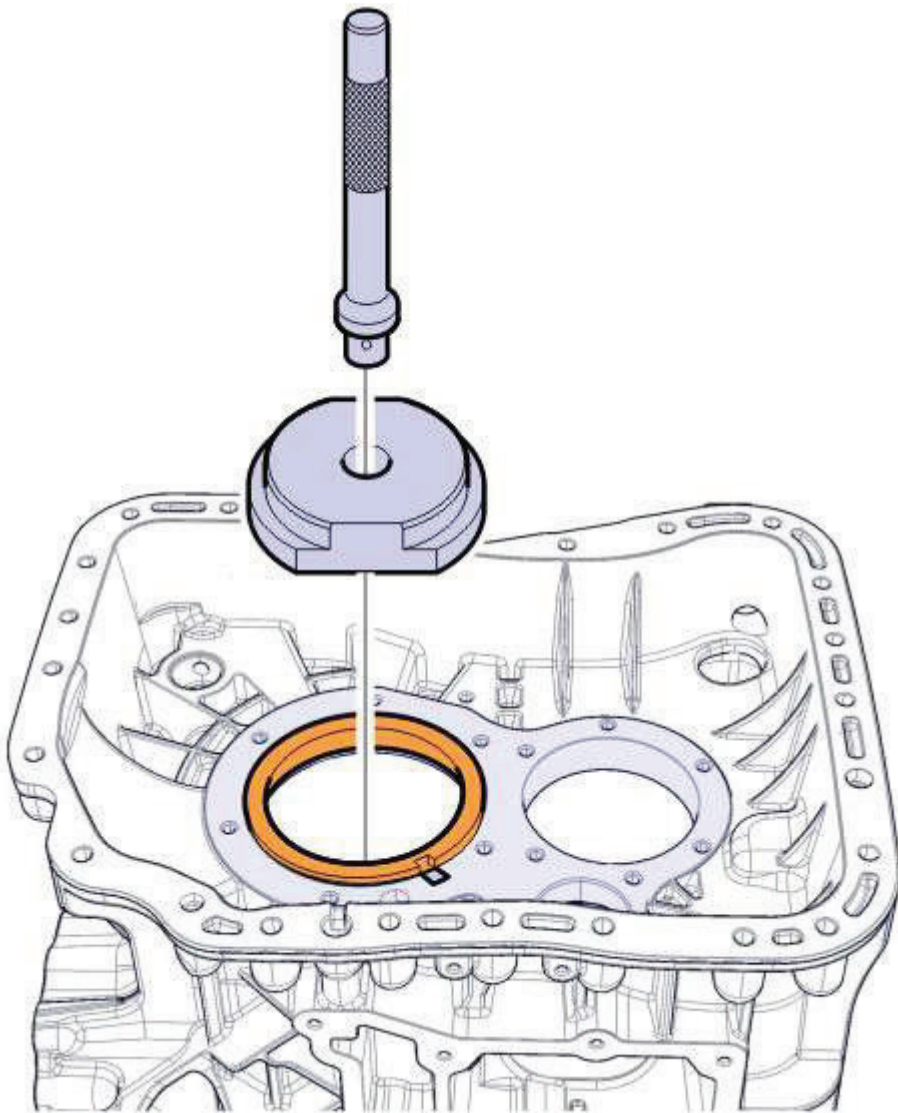

**152** Remover a válvula.

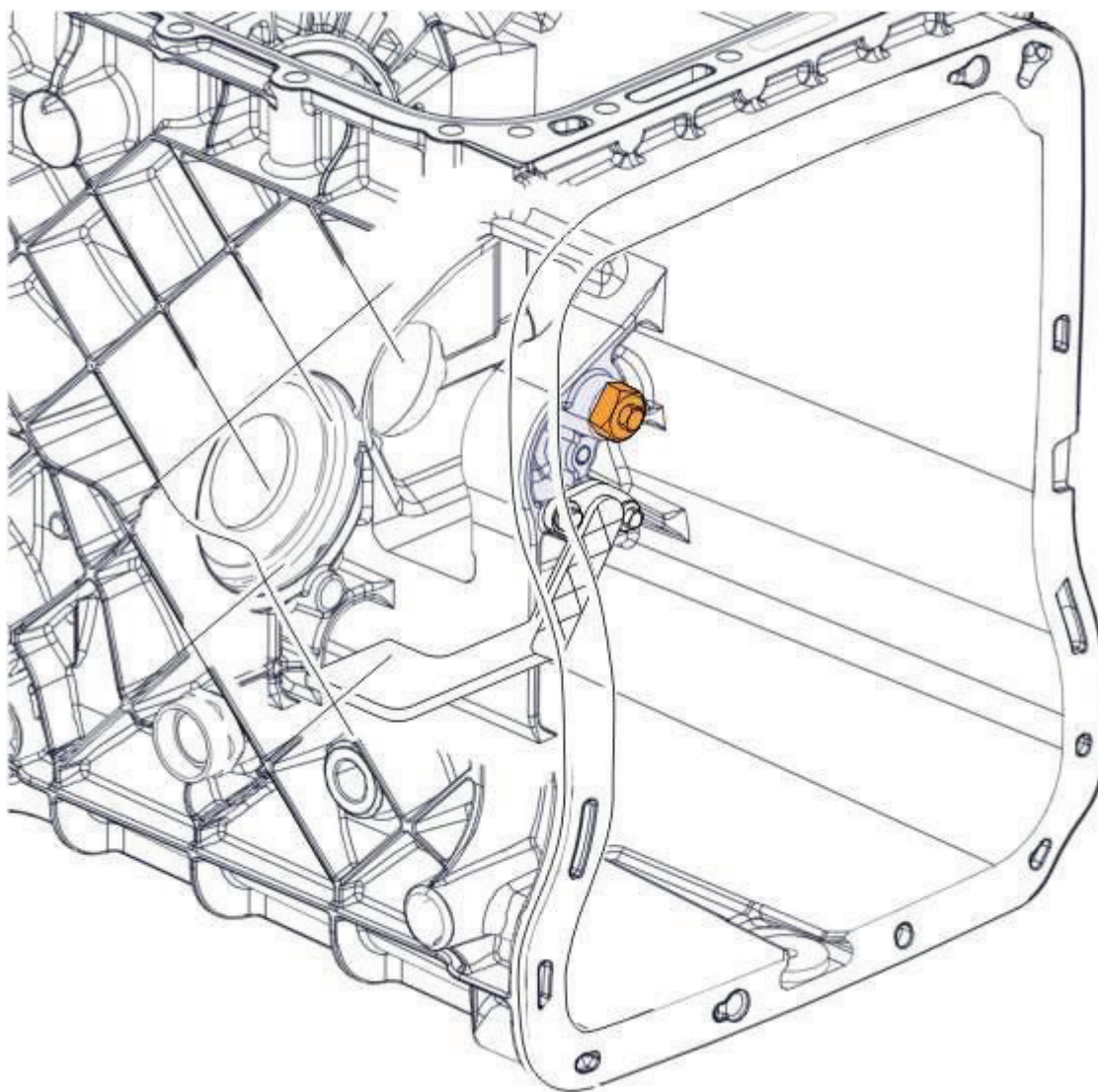

153	Remova os parafusos.
-----	----------------------

154	Remover o tubo.
-----	-----------------

155	Remova o anel O.
-----	------------------

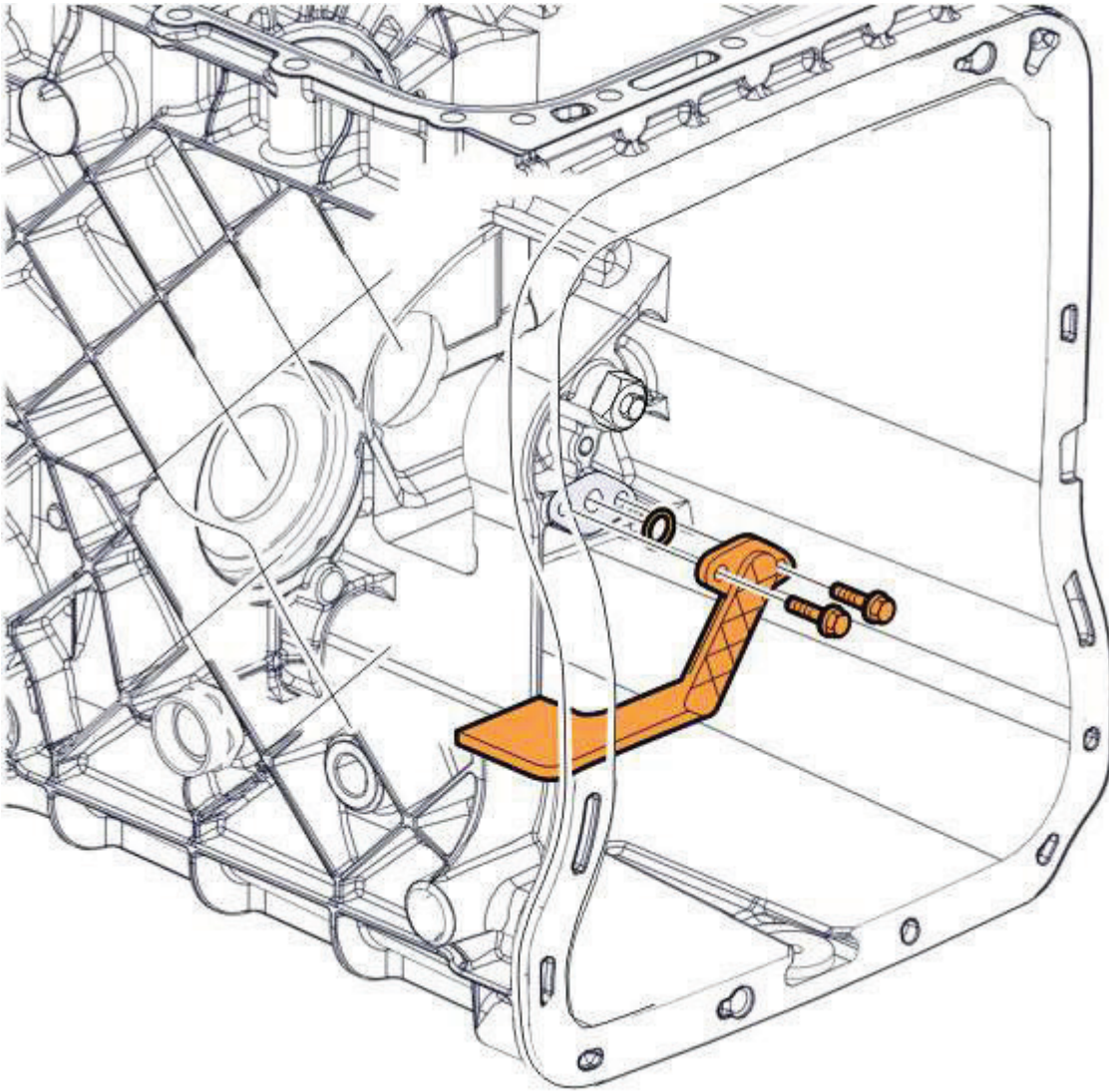

**156** Limpar todas as peças.

**157** Verifique se as peças apresentam desgaste ou dano.

<b>i</b>	<b>Nota</b> Trocar peças danificadas e desgastadas.
----------	--

**158** Lubrificar as peças.

<b>Material necessário</b>
<a href="#">Óleo da caixa de mudanças</a>

**159** Marque as posições dos pinos.

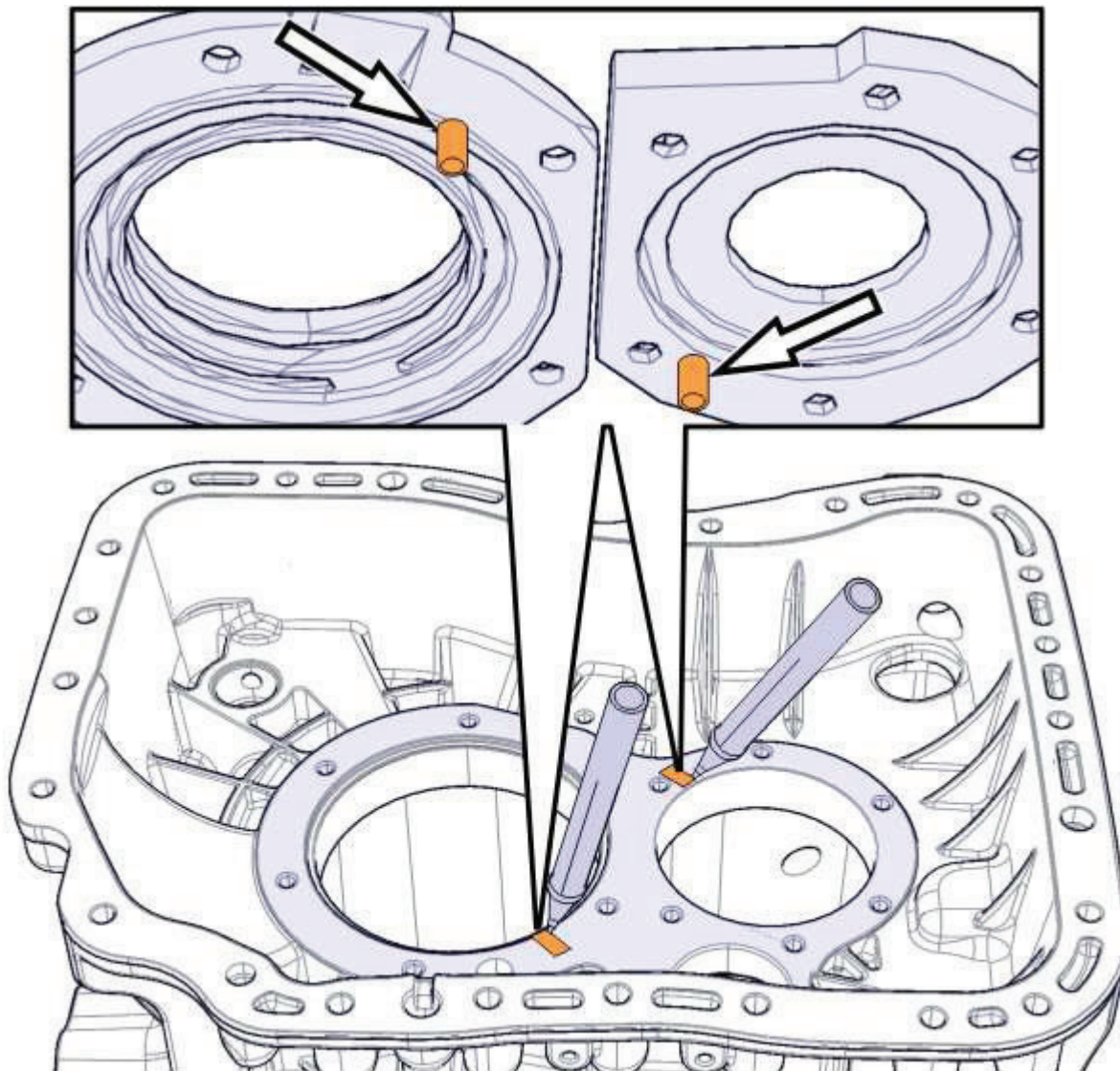

160 Posicionar as pistas externas.

**Dados técnicos**

Pista externa, distância acima da parte inferior do alojamento da caixa de mudanças. (A)	5 mm
--	------

**i** **Nota**  
Alinhar a ranhura em cada pista externa com cada marcação do pino de travamento.

**i** **Nota**  
Manter a distância (A) da parte inferior da carcaça.

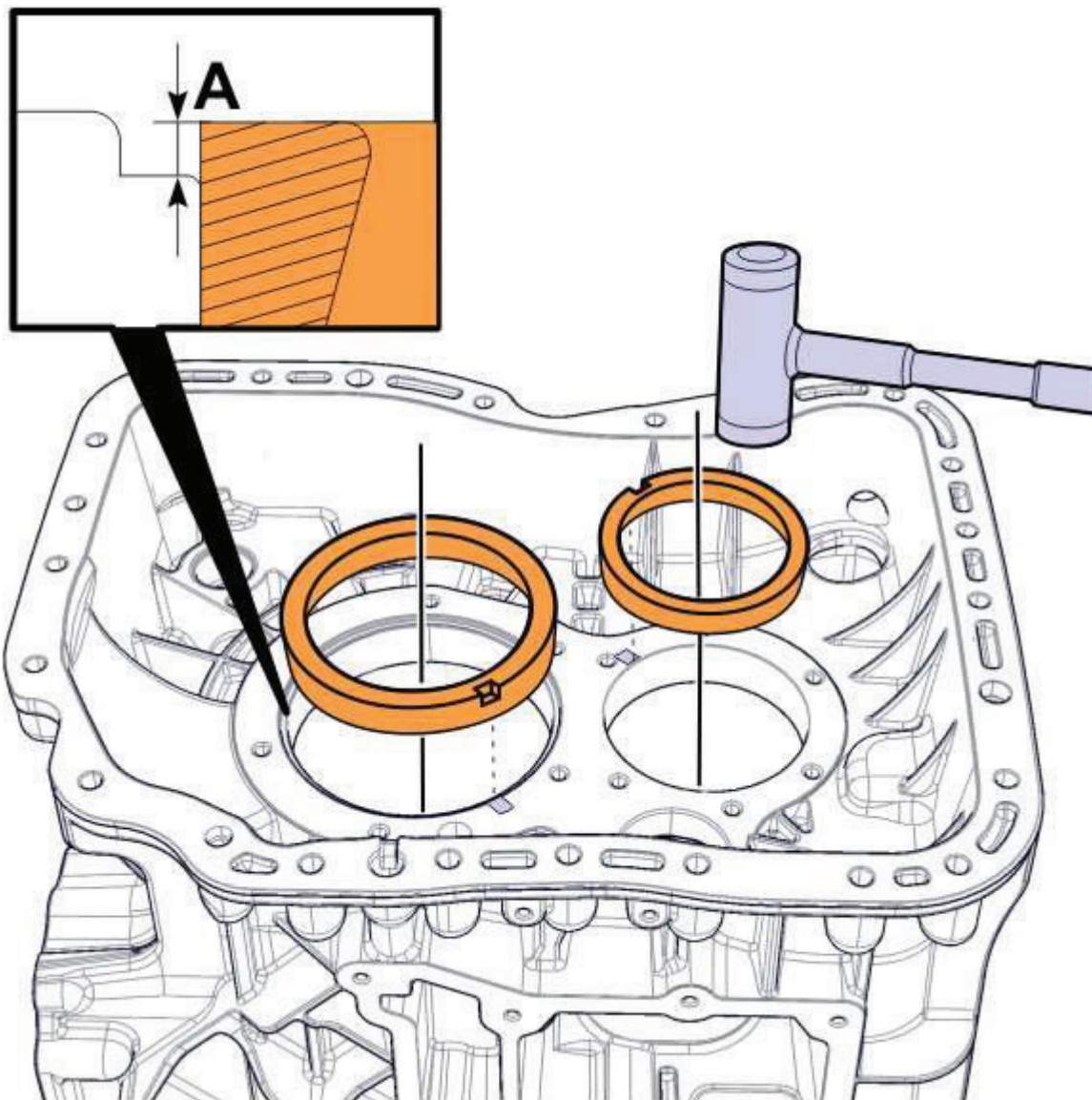

161 Instale a pista exterior.

**Material necessário**

manípulo

mandril



**Nota**

Não inserir a pista externa muito longe: a tampa do rolamento se assenta na posição correta.

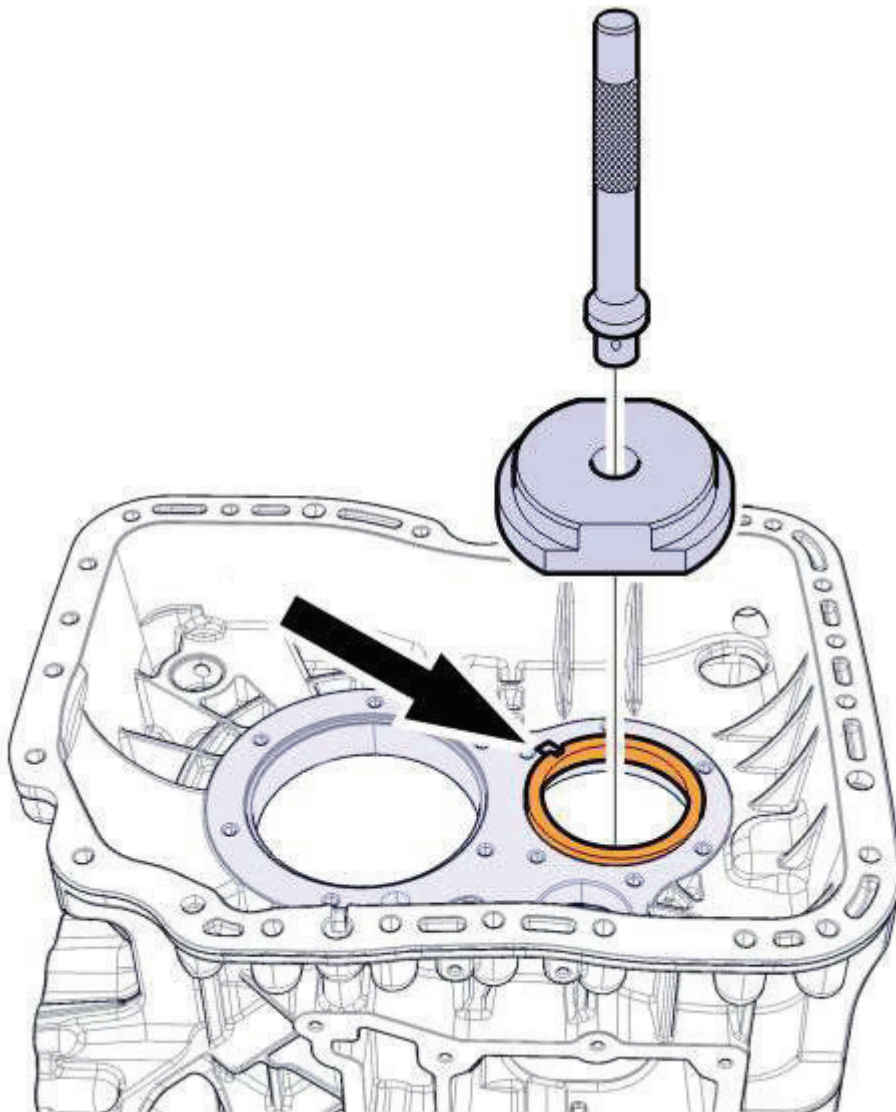

**162** Instale a pista exterior.

**Material necessário**

manípulo



mandril



**Nota**

Não inserir a pista externa muito longe: a tampa do rolamento se assenta na posição correta.

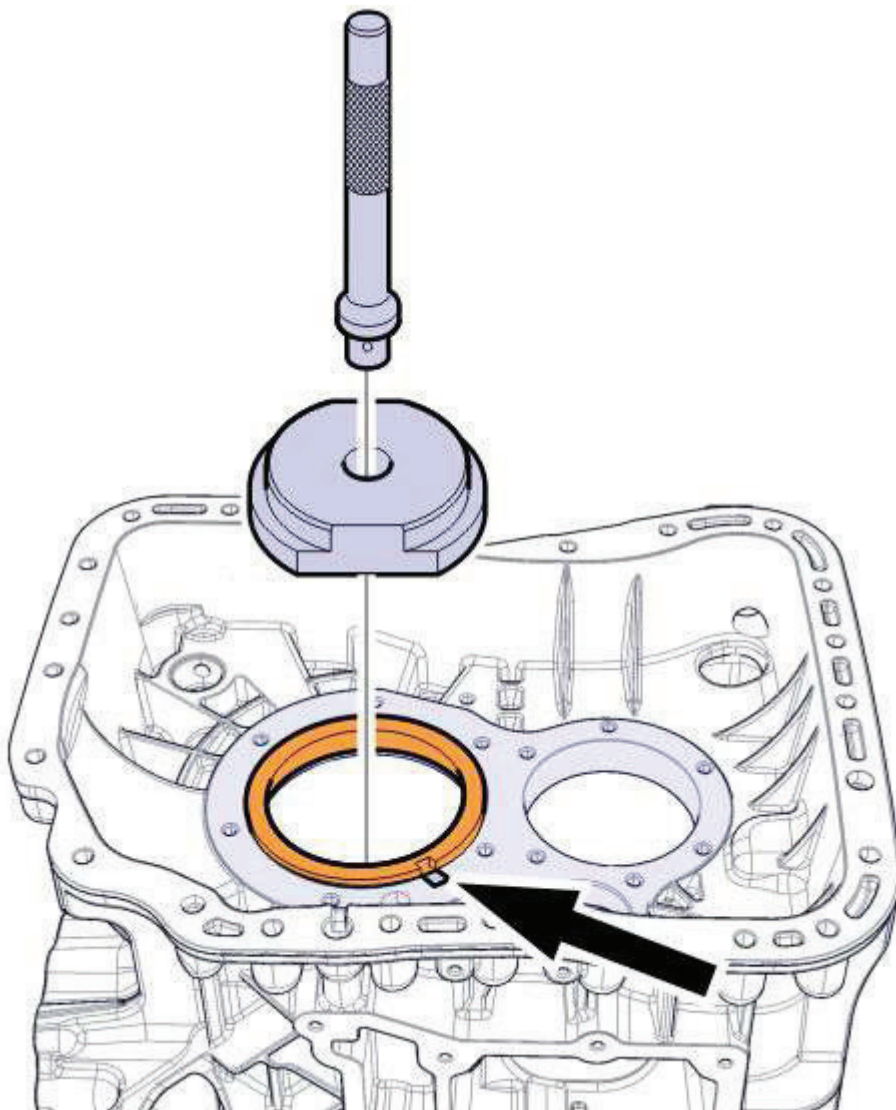

**163** Instale o anel em O.



**Nota**

Usar uma peça nova.

**164** Instalar o tubo.

**165** Instale os parafusos.

**166** Aperte os parafusos com torque.

**Torque**

Tubo de sucção, parafuso

24 ±4 Nm



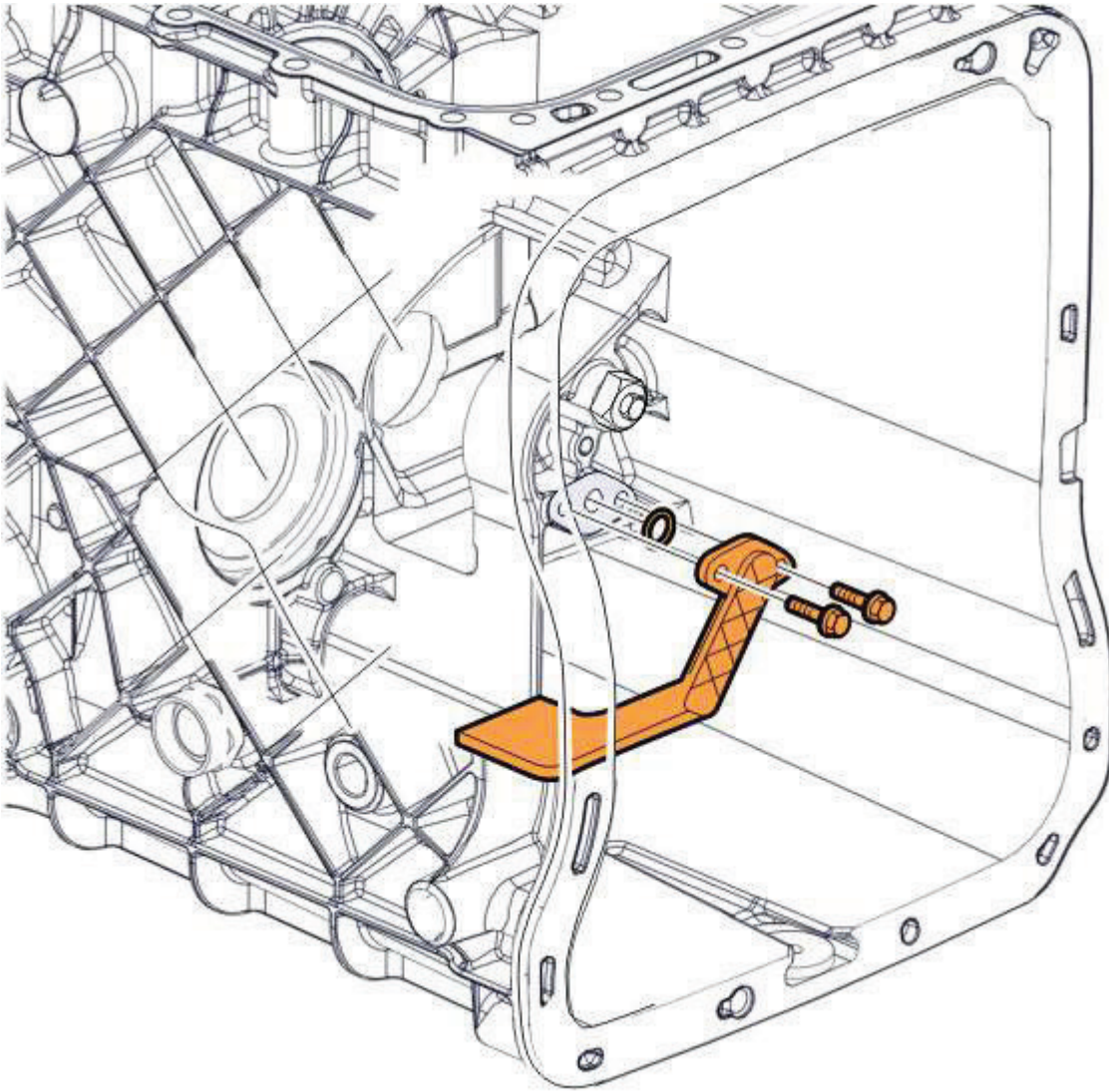

**167** Instalar a válvula.



**Nota**

Usar uma peça nova.



**Nota**

Certificar-se de que haja Loctite na rosca da válvula.

**168** Aperte a válvula com o torque adequado.

**Torque**

Válvula de descarga

48 ±8 Nm

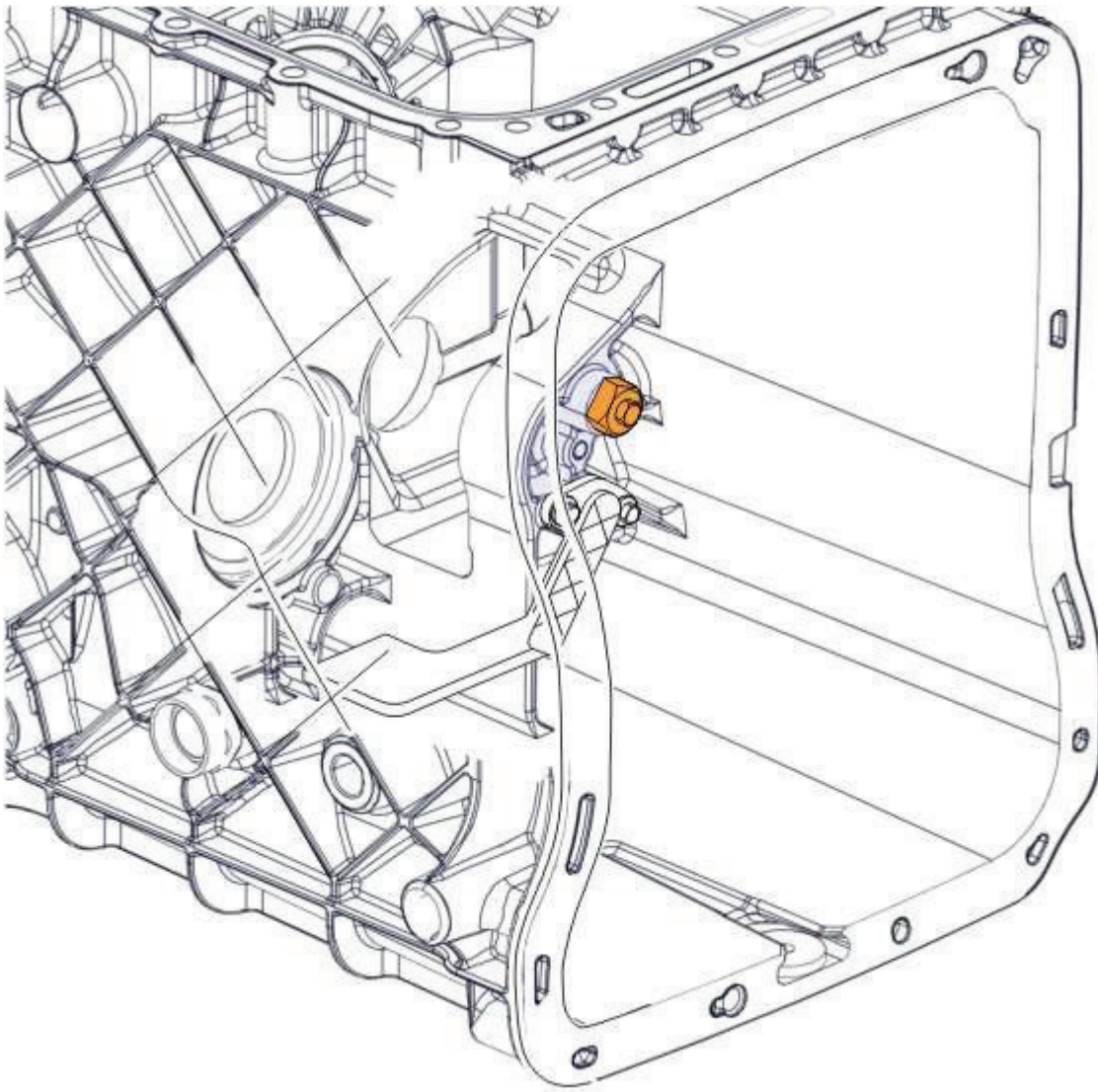

**169** Instale as ferramentas.

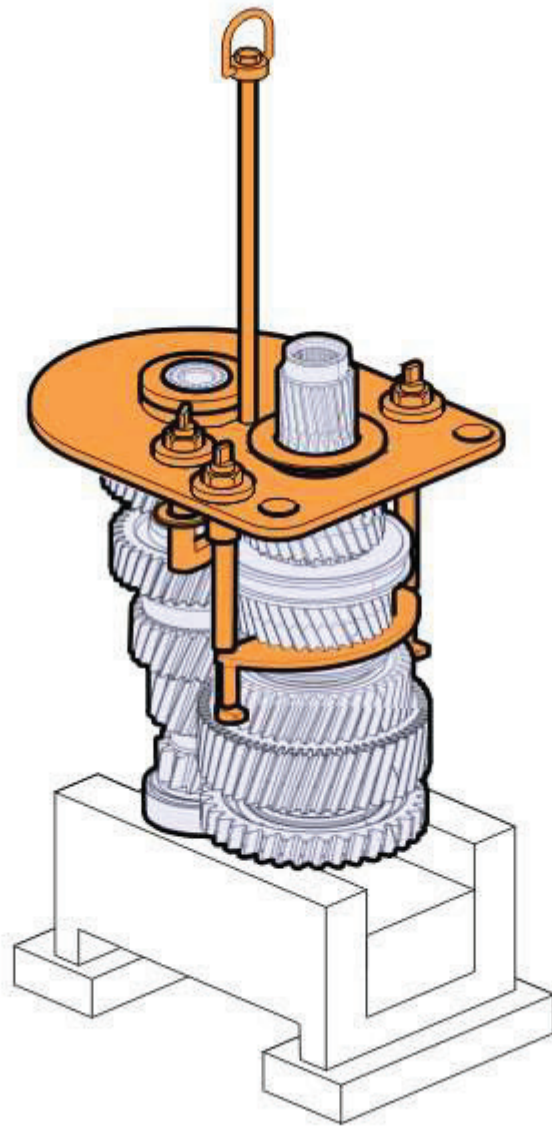

170 Instalar os conjuntos do eixo.



**Nota**

Tome cuidado para não danificar a roda do sensor.

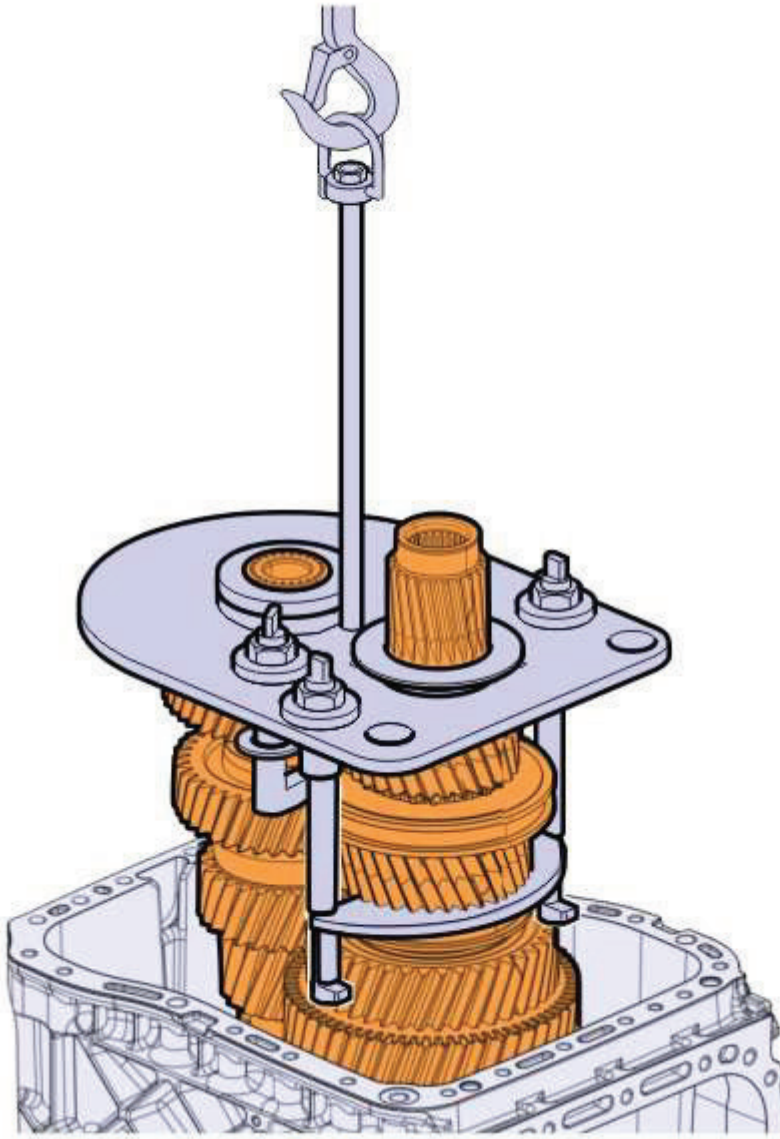

171 Instale o ímã.

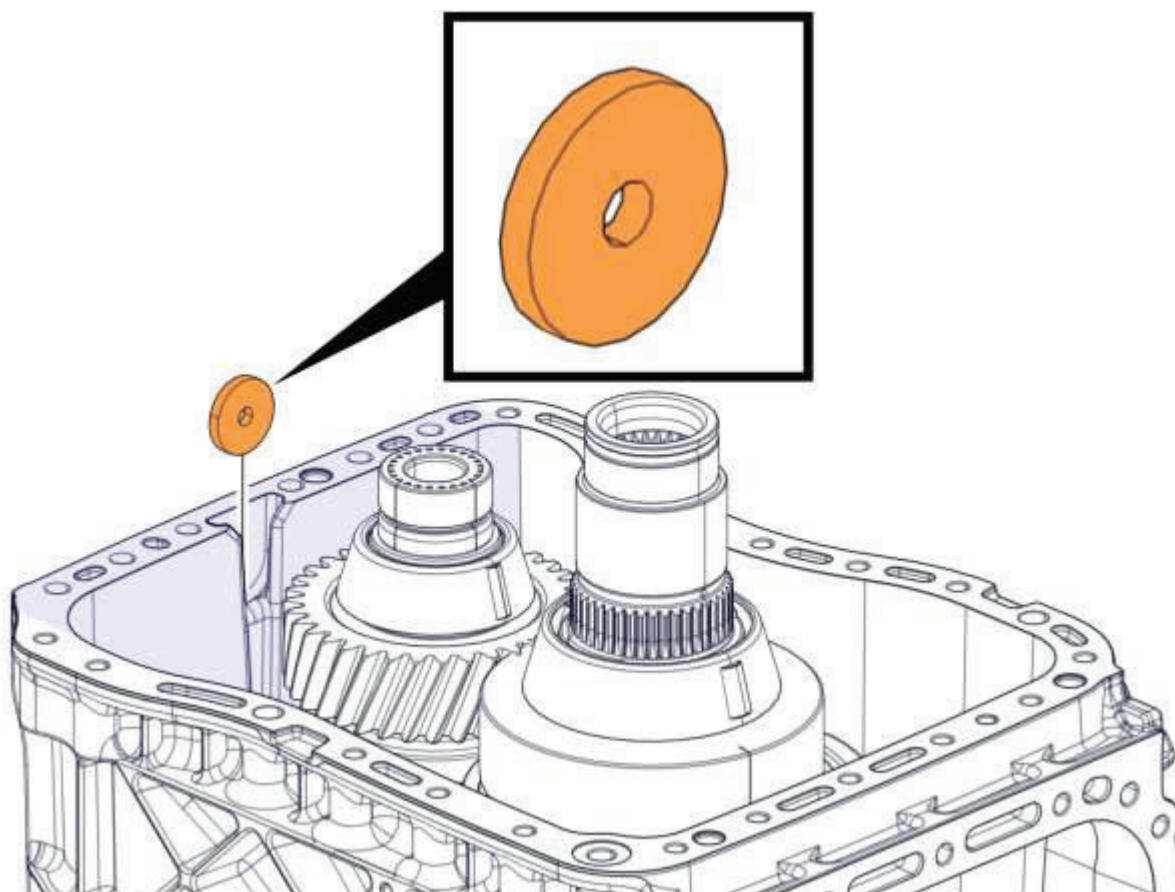

172 Execute este procedimento quando a condição abaixo for atendida.

**Condições**

- Se a carcaça ou os rolamentos são trocados.

▶ Instalar os rolamentos.

▶ Marcar a posição dos pinos.

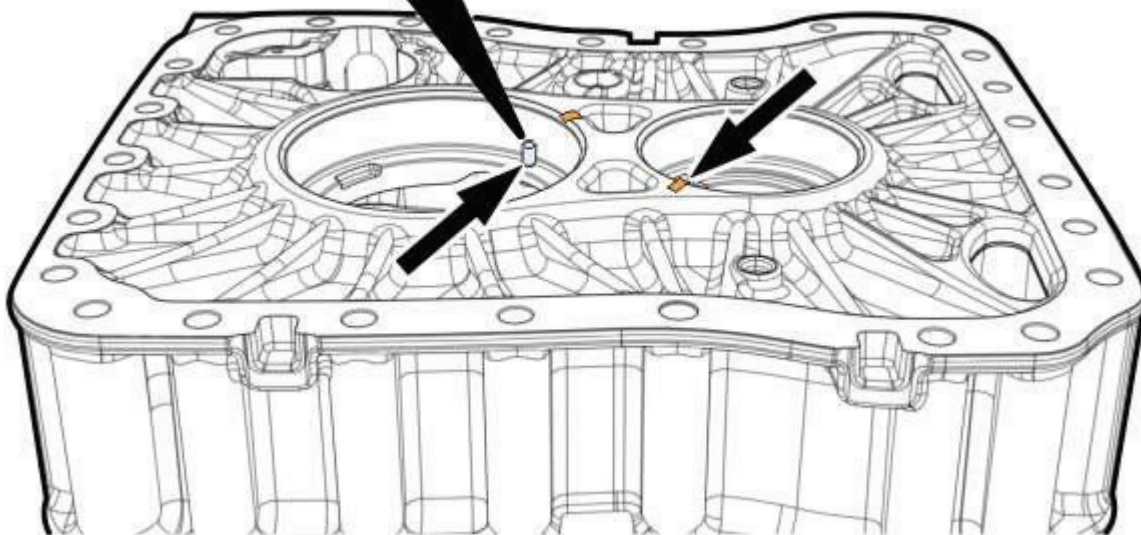
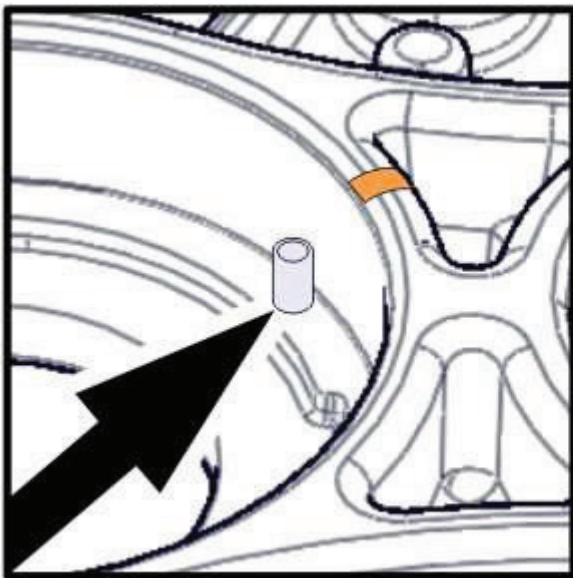

► Posição da pista externa.



**Nota**

Alinhar a ranhura em cada pista externa com cada marcação do pino de travamento.

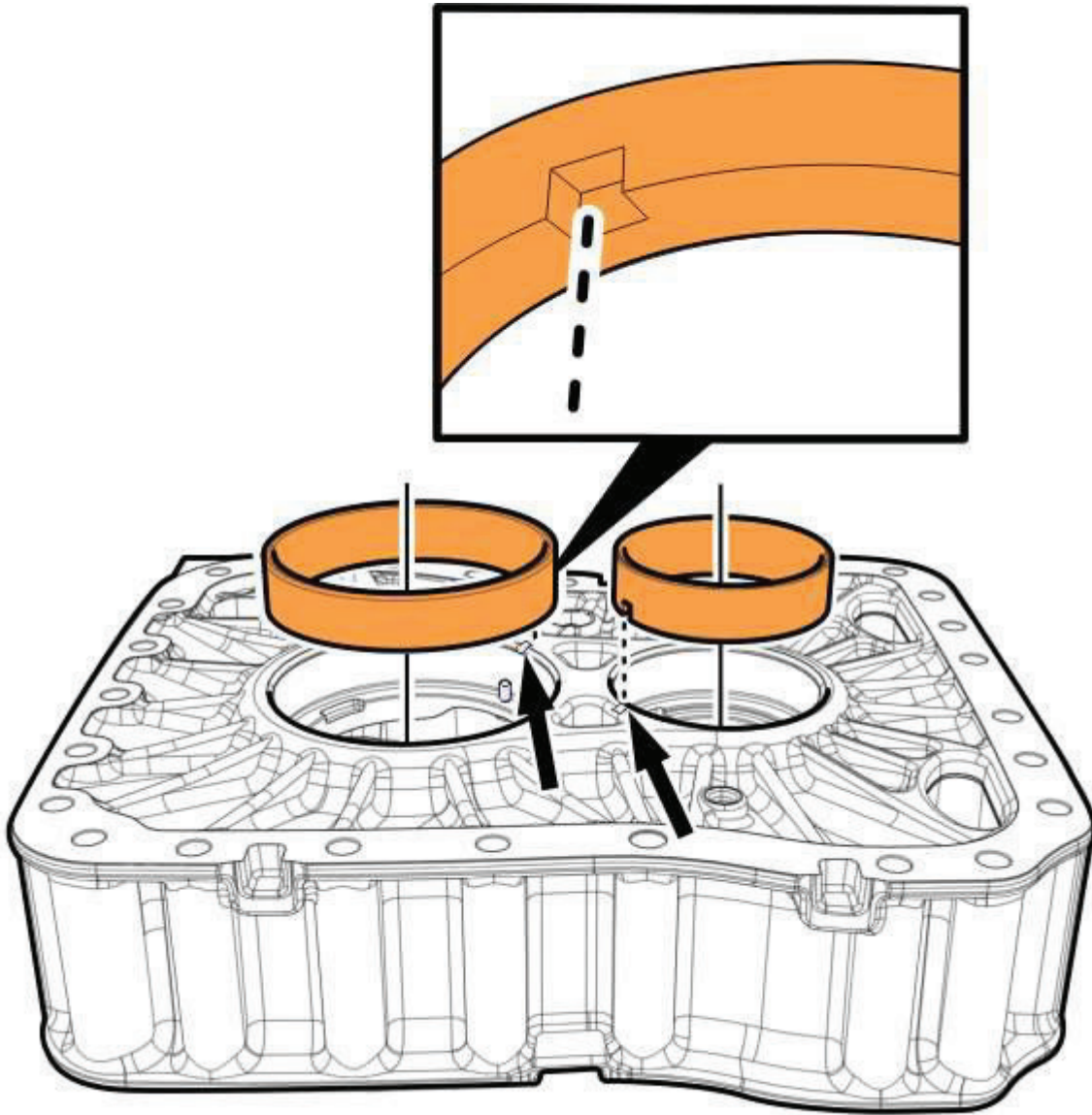

- ▶ Instalar a ferramenta (A).

**Material necessário**

mandril



**Nota**

Ferramenta (A) está apoiando a carcaça.

- ▶ Instalar o rolamento.

**Material necessário**

PUNÇÃO OCO



**Nota**

Tomar cuidado para não danificar o componente.

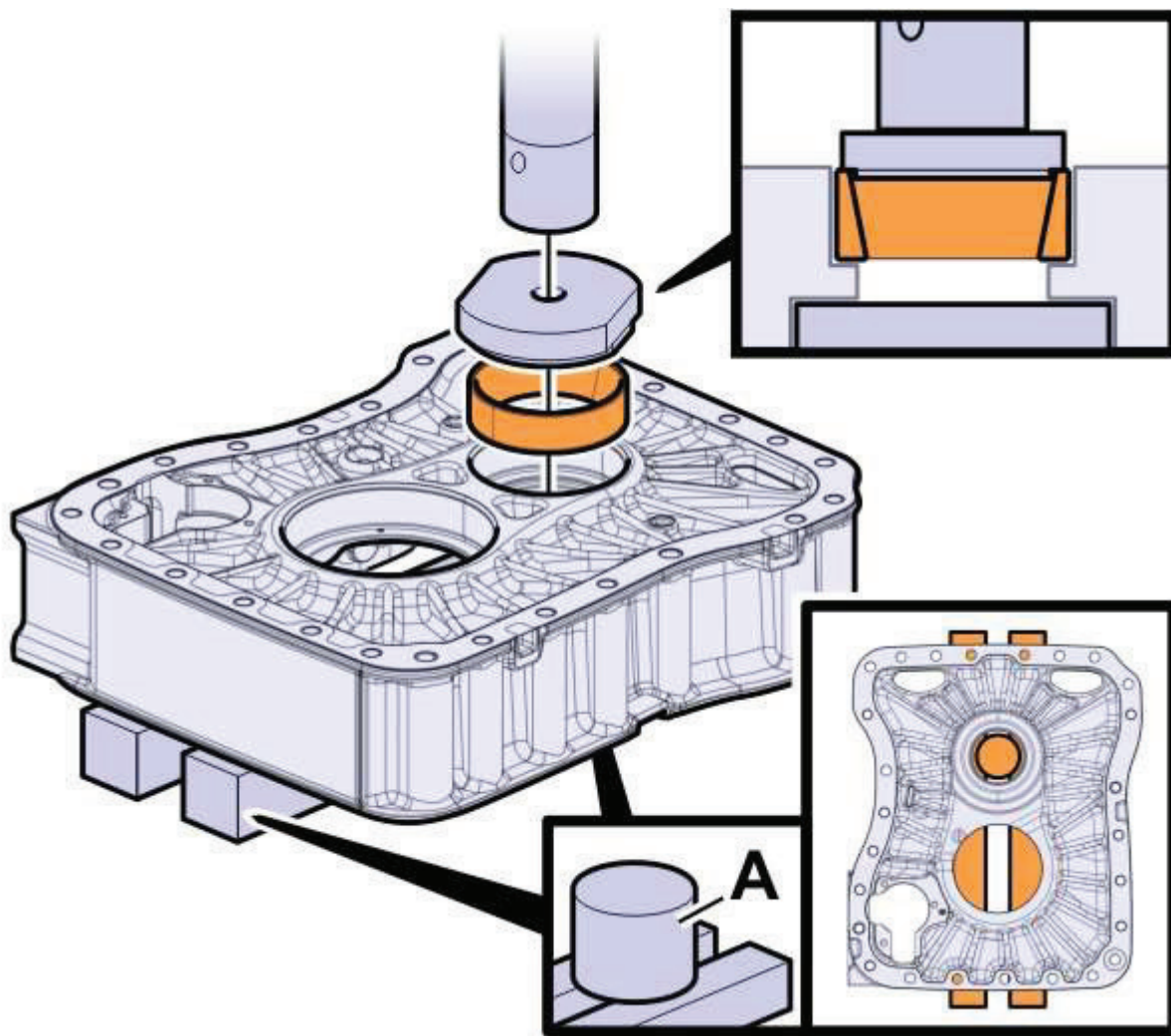

▶ Instalar a ferramenta (A).

**Material necessário**

mandril



**Nota**

A ferramenta (A) está apoiando a carcaça.

▶ Instalar o rolamento.

**Material necessário**

PUNÇÃO OCO



**Nota**

Tomar cuidado para não danificar o componente.



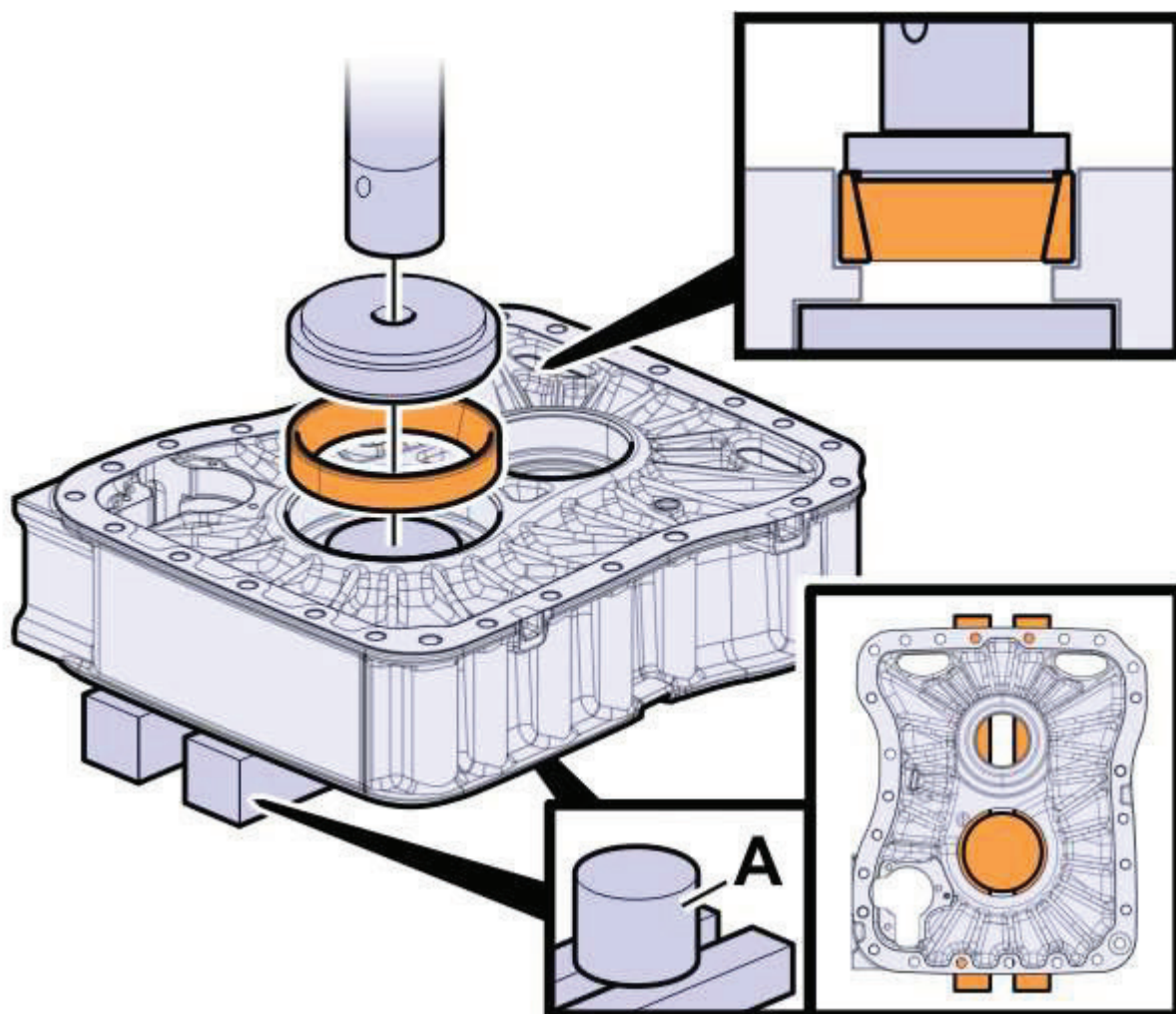

173 Instalar as ferramentas (A).

**Material necessário**

GUIA

174 Instalar a junta.



**Nota**

Usar uma peça nova.



**Nota**

Limpar as superfícies de contato.

175 Instale a carcaça.



**Nota**

Assegurar-se de que os pinos de localização estejam corretamente instalados.

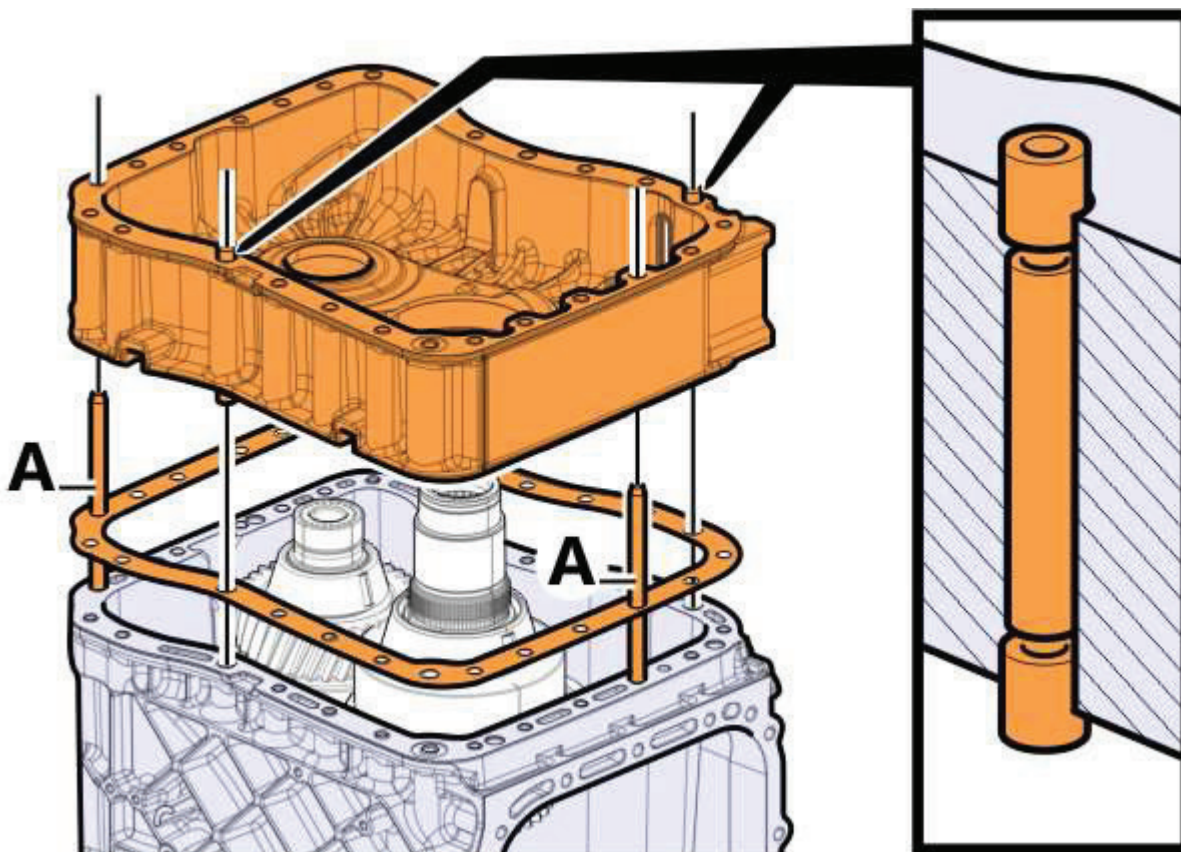

176 Instalar a luva.



**Nota**

Instalar conforme indicado.

177 Instalar o garfo seletor.

178 Instalar os parafusos.

179 Apertar os parafusos com o torque especificado.

**Torque**

Inibidor de mudança de marcha, parafuso	28 ±5 Nm
---	----------